

Improved Performance of Reed-Solomon Decoding with the use of Pilot Signals for Erasure Generation

Lisa Welburn and James K. Cavers
 School of Engineering Science, Simon Fraser University
 Burnaby, B.C., V5A 1S6, Canada
 Tel: (604) 291-4371 - Fax: (604) 291-4951
 Email: lwelburn@cs.sfu.ca, cavers@sfu.ca

Abstract— The performance of a Reed-Solomon (RS) decoder can be improved by allowing Errors and Erasures (E&E) decoding if each error location is correctly identified, or “flagged”, and considered as an erasure. However, in order to be effective, it is imperative that the erasure flagging is accurate. In this paper, we propose the use of pilot signals in a new method for flagging erasures. A Bayesian method for optimum character erasure flagging is derived which uses both the received data signals and the channel estimates provided by pilot signals, and a simpler method is presented which flags erasures on a modulation symbol basis. Our simulation results demonstrate that combining pilot signals with E&E decoding results in significant transmit power savings.

I. INTRODUCTION

Reed-Solomon codes are popular in mobile communications as a result of their ability to handle relatively long error bursts. These codes are also attractive since they allow E&E decoding, a technique which is able to double the correction capability of the code. In effect, this doubles the effective order of diversity of the code when characters are interleaved, leading to major performance improvements. However, in order to realize these potential performance gains, the erasure flagging must be extremely reliable.

A number of erasure flagging methods have been proposed for communication systems with varying degrees of success. Some of the schemes include the use of envelope detector outputs in a noncoherent communication system [1]-[3]. Another erasure flagging method involves dividing and labelling signal constellations into “good” and “bad” regions [4]. It has also been shown in [5] that the feedback power control in a direct sequence code division multiple access (DS-CDMA) system can be used in an error detecting algorithm.

In this paper, we present a new way to flag erasures, based on the side information provided by pilot signals. Although pilot signals have often been used for detection, [6] - [8], to date they have not been applied to E&E decoding. We derive an optimum character erasure flagging method based on Bayesian decision theory, using the channel estimates provided by pilot signals along with the received data signals. In addition to the optimum Bayesian technique, we describe a simpler method which flags erasures on a modulation symbol basis. Both the Bayesian and

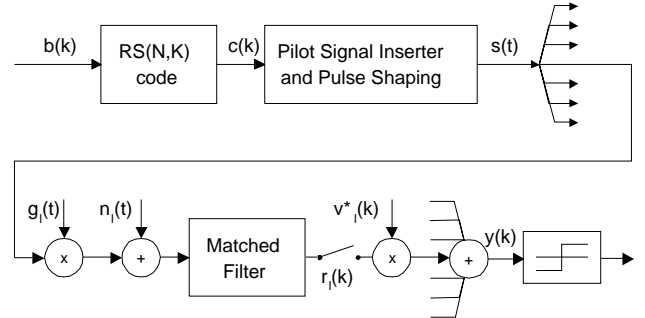

Fig. 1. Block Diagram

the modulation symbol erasure flagging algorithms can be employed with many modulation formats such as BPSK, QPSK, and 8PSK, and they can also be used in conjunction with diversity reception.

The performance of the symbol erasure flagging algorithm approaches the optimal Bayesian method, and both of these are shown to be far superior to errors only decoding and to the simplest erasure flagging, which uses instantaneous received power alone.

II. SYSTEM MODEL

A block diagram of the system is shown in Fig. 1. The input data, $b(k)$, can be BPSK, QPSK, or 8PSK. The data is divided into frames of Q modulation symbols to create the Reed-Solomon characters. $\mathbf{b}_i = (b_i(1), b_i(2), \dots, b_i(Q))$ where \mathbf{b}_i is the i^{th} Reed-Solomon character. A Reed-Solomon (N, K) coder converts K information characters into a block of N characters where $N > K$.

Following the RS coder is pilot signal insertion and pulse shaping. The inserted pilot signals provide the receiver with channel estimates, and they can take the form of either pilot tones [6] or pilot symbols [7]. The transmitted waveform which includes pilot signals is given as:

$$s(t) = A \sum_{k=-\infty}^{\infty} c(k)p(t - kT) \quad (1)$$

where A is an amplitude factor, $p(t)$ is a unit energy pulse, and T is the symbol duration.

The data is transmitted over a number of independent Rayleigh flat fading channels with additive noise. $g_i(t)$ denotes the channel's complex gain which includes both fading and frequency offset. If isotropic scattering is assumed,

The work reported here was supported by the Natural Sciences and Engineering Research Council of Canada postgraduate scholarship program.

the autocorrelation function of each channel is [9]:

$$R_g(\tau) = \sigma_g^2 \exp(j2\pi f_o \tau) J_o(2\pi f_D \tau) \quad (2)$$

where f_o refers to the frequency offset. The channels are complex Gaussian with variance σ_g^2 and a Doppler spread of f_D . $n_l(t)$ is the additive white Gaussian noise (AWGN); it is a complex Gaussian process with zero mean and a power spectral density of N_o . The impulse response of the matched filter is $p^*(-t)/\sqrt{N_o}$. The noise normalization results in AWGN with unit variance, $\sigma_n^2 = 1$.

The samples at the matched filter output are given by:

$$r_l(k) = \frac{Ag_l(kT)}{\sqrt{N_o}} c(k) + n_l(k) = u_l(k)c(k) + n_l(k) \quad (3)$$

The channel estimate, $v_l(k)$, is an estimated $u_l(k)$ obtained from pilot signals, so that $u_l(k) = v_l(k) + e_l(k)$, where $e_l(k)$ is the estimation error. If $v_l(k)$ is optimal, the variance of the estimation error is minimized, and the error sequence is uncorrelated with the estimate [10]. The magnitude of σ_e^2 depends on the type of pilot signals used, and the accuracy of the implementation.

The received samples in (3) are combined with the channel estimates to form the maximum likelihood (ML) decision variables.

$$y(k) = \sum_{l=1}^L r_l(k)v_l^*(k) \quad (4)$$

The decision variables, $y(k)$, at the detector can be thresholded to detect the input data and to flag erasures on suspicious characters. Specific thresholding techniques for erasure flagging will be discussed in further detail in Sections III and IV.

III. CHARACTER ERASURE FLAGGING

The optimum Bayesian erasure flagging method places a threshold on the posterior probability, $P(\mathbf{c}|\mathbf{r}, \mathbf{v})$. $P(\mathbf{c}|\mathbf{r}, \mathbf{v})$ is the probability of a RS character given samples of received signals and channel estimates which span the entire character. \mathbf{c} includes the Q symbols which compose the RS character; \mathbf{r} is a total of LQ matched filter outputs received on L separate channels; and \mathbf{v} includes LQ channel estimates on the L diversity channels. The decoded character maximizes $P(\mathbf{c}|\mathbf{r}, \mathbf{v})$. If the maximum $P(\mathbf{c}|\mathbf{r}, \mathbf{v})$ is not large, an erasure should be flagged, since the probability of decoding the wrong RS character is relatively high.

The posterior probability, $P(\mathbf{c}|\mathbf{r}, \mathbf{v})$, can be written in terms of the forward probabilities, $P(\mathbf{r}|\mathbf{c}, \mathbf{v})$, if we use Bayes' theorem and assume that the characters are equiprobable. $P(\mathbf{r}|\mathbf{c}, \mathbf{v})$ can then be written in terms of $P(r_l(k)|c(k), v_l(k))$ by using the fact that $r_l(k)$ is independent for different k and l values when conditioned on $c(k)$ and $v_l(k)$, and assuming independent fading, $r_l(k)$ and $v_l(k)$ are independent across the channels when conditioned on $c(k)$.

Given $c(k)$ and $v_l(k)$, $r_l(k)$ is Gaussian with mean $c(k)v_l(k)$ and variance $\sigma(k)^2 = |c(k)|^2 \sigma_e^2 + \sigma_n^2$. For BPSK, QPSK, and 8PSK, $\sigma(k)^2$ remains constant for all data symbols. Therefore, $\sigma(k)^2$ will be replaced by σ^2 . Once all common terms are cancelled, $P(\mathbf{c}_o|\mathbf{r}, \mathbf{v})$ becomes:

$$P(\mathbf{c}_o|\mathbf{r}, \mathbf{v}) = \frac{\prod_{k=1}^Q \exp\left(\frac{1}{\sigma^2} (\text{Re}[y(k)c_o^*(k)])\right)}{\sum_j \prod_{k=1}^Q \exp\left(\frac{1}{\sigma^2} (\text{Re}[y(k)c_j^*(k)])\right)} \quad (5)$$

where \mathbf{c}_o is the decoded character, \mathbf{c}_j is the j^{th} of $2^{N_b Q}$ characters, and the ML decision statistic, $y(k)$, is given in (4). The real and imaginary components of $y(k)$ are given by $y_r(k) = \text{Re}[y(k)]$ and $y_i(k) = \text{Im}[y(k)]$ respectively.

For BPSK, QPSK, and 8PSK, it can be shown that (5) simplifies; the denominator can be factored and rewritten as a product of sums. Setting a threshold on the log likelihood results in the final form of the optimal Bayesian erasure flagging function. The optimal erasure flagging function for BPSK is as follows:

$$\ln(P(\mathbf{c}_o|\mathbf{r}, \mathbf{v}))_B = \sum_{k=1}^Q \left(\frac{|y_r(k)|}{\sigma^2} - \ln \left(\cosh \left(\frac{y_r(k)}{\sigma^2} \right) \right) \right) \quad (6)$$

The QPSK and 8PSK erasure flagging functions are not shown here, but their log likelihoods also reduce to a single summation over the Q symbols in the RS character.

The regions in y space defined by the optimal erasure flagging function in (6) are shown in Fig. 2. For simplicity, this figure depicts a BPSK signal with $Q = 2$ bits per RS character. Without loss of generality we assume that $\mathbf{c}_o = [+1, +1]$. The signal is decoded correctly only if it occupies the y space in quadrant 1; otherwise the character is erroneous. The curved boundaries are induced by the threshold on (6), and the shape of the erasure region changes with the threshold as can be seen in the figure. The areas which lead to false alarms and missed errors can be seen in the diagram for the threshold which results in the approximately diamond shaped erasure region.

Threshold placement plays an extremely important role in the performance of any E&E decoder; therefore, the best operating point for the Bayesian based erasure flagging will be discussed later in Section VI. In the next section a simpler erasure flagging method is discussed.

IV. SYMBOL ERASURE FLAGGING

A simpler erasure flagging method consists of flagging erasures on a symbol by symbol basis. The RS character is considered to be an erasure if any of its symbols have been flagged, on the grounds that the character is in error if any of its symbols are in error. Essentially we place individual thresholds on the $y(k)$ values of the Q symbols, rather than a single threshold on the sum as in (6). The BPSK, QPSK, and 8PSK symbol based erasure flagging functions are given below for $k = 1, 2, \dots, Q$.

$$T_{BPSK} = \min_k |y_r(k)| \quad (7)$$

$$T_{QPSK} = \min_k [|y_r(k)|, |y_i(k)|] \quad (8)$$

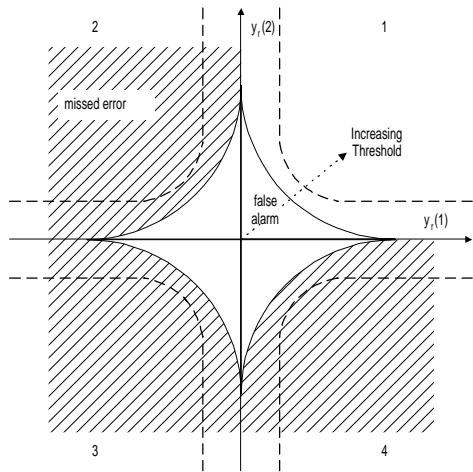

Fig. 2. y Space for Character Based Flagging

$$T_{8PSK} = \min_k [|y_r(k)|, |y_i(k)|, ||y_r(k)| - |y_i(k)||] \quad (9)$$

The erasure region shape produced by T_{BPSK} is similar to that for character erasure flagging with a large threshold. Therefore, its shape resembles the region described by the dashed line in Fig. 2 with squared corners instead of rounded corners. The performance of a RS decoder with both symbol and optimal Bayesian erasure flagging will be investigated in the following two sections.

V. ANALYSIS

A Reed-Solomon (N, K) code consists of K information characters and $(N - K)$ parity check characters. RS codes are formed by setting $N = 2^{N_b Q} - 1$ and $K = 1, 2, 3, \dots, N - 1$ where Q is the number of symbols in the RS character, and N_b is the number of bits/symbol. RS codes are capable of correcting $[(N - K)/2]$ errors. However, if the location of an error can be predicted, the RS code can correct t errors and q erasures where the errors and erasures are related as follows: $2t + q = N - K = T$. Therefore, twice as many errors can be corrected if each error location is correctly identified. However, the erasure flagging is error prone, and the two types of errors which can occur are false alarms and misses. In order for the erasure flagging to be advantageous it must be accurate; the probability of miss and, especially, the probability of false alarm should be kept low.

The probability of false alarm is defined as the probability of an erasure given that the character is correct, $P_{fa} = P(e|\bar{h})$, where e denotes an erasure and h is a character error. The probability of a miss is defined as the probability of no erasure given that the character is in error, $P_m = P(\bar{e}|h)$. For perfect interleaving by either modulation symbol or by RS character, the probability of

decoder failure can be written as:

$$P_f = \sum_{q=0}^T \left\{ \sum_{t=\lfloor (T-q)/2 \rfloor + 1}^{N-q} P_t P_q \right\} + \sum_{q=T+1}^N P_q \quad (10)$$

where the probability of q erasures is $P_q = \binom{N}{q} P_e^q (1 - P_e)^{N-q}$, and the probability of t errors in the remaining $N - q$ unflagged positions is $P_t = \binom{N-q}{t} P(h|\bar{e})^t (1 - P(h|\bar{e}))^{N-q-t}$. Here P_e refers to the probability of a character erasure which can also be calculated with the binomial distribution if perfect interleaving by symbol is assumed. However, RS codes perform best when interleaved by character since one symbol error causes a RS character error, and errors in fading channels tend to occur in bursts.

The theoretical calculations for P_f for both character and symbol based erasure flagging become increasingly complex with large Q values and data which is interleaved by character. Therefore, simulations will be used to determine these probabilities.

VI. SIMULATIONS

The simulated system transmits each character over L independently fading channels, and the characters are transmitted separately in order to achieve perfect interleaving by character. Flat Rayleigh fading channels are assumed with a frequency offset of zero and a Doppler spread of $f_D T = 0.01$ where T is the symbol duration. AWGN with unit variance is added to the signal, and the matched filter performs noise normalization by dividing through by $\sqrt{N_0}$. In the simulations, Pilot Symbol Assisted Modulation (PSAM) [7] is used to generate the channel estimates for both detection and erasure flagging. The pilot symbol frame length is set to $F = 16$, and the interpolator length is equal to 11.

The probabilities of false alarm, miss, and character error are determined by computer simulation for three different types of erasure flagging: character, symbol, and conventional erasure flagging which is based on the instantaneous received power alone. Once the appropriate erasure flagging function is calculated, it is thresholded to flag erasures on the RS characters. A range of thresholds is implemented, and the false alarm rate and miss rate are calculated at each threshold. The optimal threshold is chosen as the one which results in the minimum decoder failure probability.

Fig. 3 contains simulated probability of decoder failure plots for a BPSK signal transmitted over one channel in a RS(31,19) code and interleaved by character. The Power, Symbol, and Character curves depict results obtained at the optimal threshold for each flagging function, and errors-only decoding is equivalent to setting the threshold to zero. The ± 5 dB SNR Error curves will be discussed later in this section. As can be seen from Fig. 3, the symbol and character erasure flagging methods give almost identical performance, and they both outperform errors-only decoding and the instantaneous power approach. The reason that the character and symbol based approaches

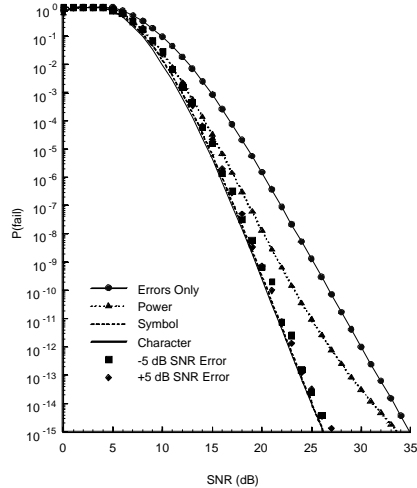

Fig. 3. Probability of decoder failure for a RS(31,19) code.

produce similar results is best understood by comparing their erasure regions (see Fig. 2). The character erasure flagging performs best with a relatively large threshold. Therefore, its erasure region has a similar shape to that produced by the symbol based erasure flagging (see Section IV). In fact, it is only in later figures at low SNR that significant differences can be observed.

Since any E&E decoder's performance depends on threshold placement, the sensitivity of the decoder to a misplaced threshold is an important factor. The optimal threshold varies with SNR; therefore, the SNR must be estimated in order to place the threshold. Sensitivity tests were performed for both symbol and character erasure flagging; however, since both of these methods outperform the instantaneous power approach, no sensitivity tests were executed for the power method. The SNR was misjudged by ± 5 dB in order to determine the sensitivity of a misplaced threshold. Fig. 3 contains the ± 5 dB results for symbol erasure flagging. As can be seen from this figure, the symbol erasure flagging method is relatively insensitive to the misplaced thresholds. The ± 5 dB test for character erasure flagging produced similar results. Since performance of both of the proposed methods remains stable with thresholds placed by misjudged SNRs, all following comparisons are made based on results obtained at optimal thresholds.

Figs. 4 and 5 show the gains achieved by the various E&E decoding methods. The gain is defined as the amount of SNR saved by using E&E as opposed to errors-only decoding. In these plots, the gain is plotted against the operating SNR. The range of SNRs changes for the two plots since we only plot the gains for decoder failure probabilities greater than or equal to 10^{-15} . A fifth order polynomial has been fitted to the data in order to smooth

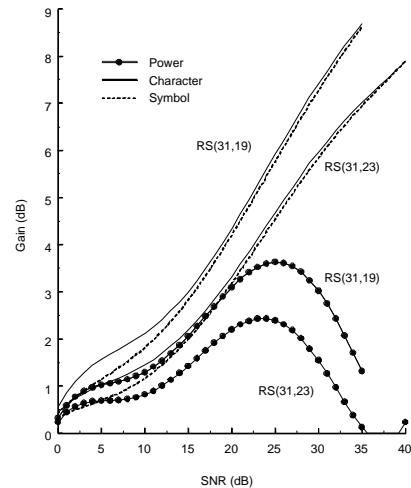

Fig. 4. Gain for BPSK RS(31,19) and RS(31,23) Codes

the curves depicting the E&E gains. Fig. 4 concentrates on BPSK modulation, and it describes the effect of code rate on the gain achieved by the E&E decoding for 5-symbol characters, or RS(31,K) codes. The difference between the pilot symbol methods and the power method remains relatively constant with a change in code rate. The simulations for 6-symbol and 8-symbol characters, RS(63,K) and RS(255,K) codes, show that the difference between the pilot symbol methods and the power method remains approximately constant with a code rate change at lower SNRs. However, as the SNR increases, this difference actually becomes larger for the higher code rate. It can also be seen from Fig. 4 that the gain resulting from power erasure flagging decreases as the SNR increases. This is because the percentage of errors due to Doppler spread is larger at high SNRs as we enter the error floor region. Since power based erasure flagging does not take Doppler spread into account, its ability to flag erasures and outperform errors-only decoding degrades as the SNR increases.

Experiments were also performed which investigated the effect of code length on the various E&E decoding methods. In general, as the code length increases, the E&E decoding gain decreases. It can be seen from Fig. 4 that for 5 symbol characters the gain resulting from pilot symbol E&E reaches 8-9 dB at the higher SNRs when the probability of decoder failure is about 10^{-15} . When the number of symbols per character is increased, the gain at a decoder failure probability of 10^{-15} is 6-7 dB for 6 symbol characters and about 4 dB for 8 symbol characters. Another way to look at this trend is that as the code length decreases, the system's overall performance begins to degrade, but the gain resulting from E&E decoding increases, helping to keep performance at an acceptable level.

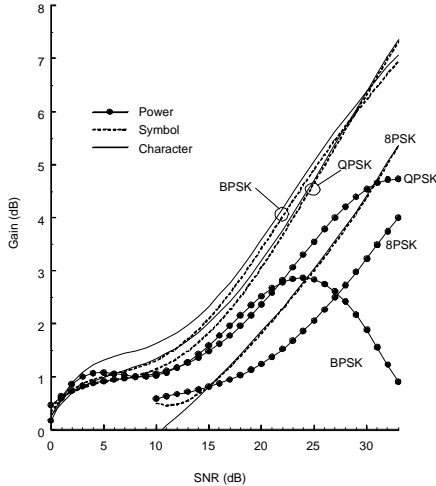

Fig. 5. Gain for BPSK, QPSK, and 8PSK RS(63,47) Codes

Fig. 5 shows the effect of modulation symbol format; it contains plots of the gain with respect to errors-only decoding for BPSK, QPSK, and 8PSK signals in RS(63,47) codes. Low SNR results have been omitted for the 8PSK results since they are estimated along the flat portion of the probability of failure curves and are therefore unreliable. As can be seen from Fig. 5, as more bits are mapped into each modulation symbol, the power method approaches the pilot symbol methods. As the number of bits per symbol increases, the power is estimated over fewer symbols, and a deficient symbol is less likely to be masked by adjacent stronger ones. However, as can be seen from this graph, both of the pilot symbol methods consistently outperform the power erasure flagging.

Simulations were also run for a system with more than one channel. A gain of approximately 3 dB was achieved for a decoder failure probability of 10^{-15} . Even though the overall gains are lower for a system which uses diversity, pilot symbol E&E still outperforms the erasure flagging which uses only received power.

VII. CONCLUSIONS

To conclude, erasure flagging based on pilot signals has the capability to improve the performance of a traditional Reed-Solomon decoder. The simulation results show that the symbol based erasure flagging performs very near the optimal Bayesian method.

Both of the pilot signal erasure flagging methods consistently outperform both errors-only decoding and E&E decoding which uses instantaneous received power alone. The use of pilot signals in E&E decoding results in a gain of approximately 8-9 dB for relatively short BPSK codes when the probability of decoder failure is about 10^{-15} . As

the code length increases, and the overall system's performance improves, the gain from pilot signal erasure flagging decreases. However, these gains are still able to reach between 4-7 dB. As more bits are mapped into each modulation symbol, the performance of power based erasure flagging begins to approach the pilot signal methods. E&E decoding also continues to improve system performance in diversity reception. The overall gains are smaller; however, the pilot signal based erasure flagging once again proves to be the most accurate method.

REFERENCES

- [1] C. W. Baum and M. B. Pursley, "Bayesian Methods for Erasure Insertion in Frequency-Hop Communication Systems with Partial-Band Interference," *IEEE Trans. Commun.*, vol. 40, pp. 1231-1238, July 1992.
- [2] C. W. Baum and M. B. Pursley, "Bayesian Generation of Dependent Erasures for Frequency-Hop Communications and Fading Channels," *IEEE Trans. Commun.*, vol. 44, pp. 1720-1729, Dec. 1996.
- [3] C. W. Baum and C. S. Wilkins, "Erasure Generation and Interleaving for Meteor-Burst Communications with Fixed-Rate and Variable-Rate Coding," *IEEE Trans. Commun.*, vol. 45, pp. 625-628, June 1997.
- [4] S. K. Wilson, J. A. C. Bingham, M. Mallory, and J. M. Cioffi, "Erasure Tagging in a Slow Rayleigh-Fading Environment," *Conf. Rec., IEEE Globecom*, vol. 2, pp. 984-988, 1994.
- [5] C. Yi and J. H. Lee, "Hybrid ARQ Scheme Using Interleaved Reed-Solomon Codes in a Power-Controlled DS-CDMA Cellular System," *IEEE Trans. Veh. Technol.*, vol. 45, pp. 683-687, Nov. 1996.
- [6] J. P. McGeehan and A. J. Bateman, "Phase Locked Transparent Tone-in-Band (TTIB): A New Spectrum Configuration Particularly Suited to the Transmission of Data Over SSB Mobile Radio Networks," *IEEE Trans. Commun.*, vol. COM-32, pp. 81-87, Jan. 1984.
- [7] J. K. Cavers, "An Analysis of Pilot Symbol Assisted Modulation for Rayleigh Fading Channels," *IEEE Trans. Veh. Technol.*, vol. 40, pp. 686-693, Nov. 1991.
- [8] P. Ho and J. H. Kim, "Pilot Symbol-Assisted Detection of CPM Schemes Operating in Fast Fading Channels," *IEEE Trans. Commun.*, vol. 44, pp. 337-347, Mar. 1996.
- [9] W. C. Y. Lee, *Mobile Communications Engineering*. New York: McGraw-Hill, 1982.
- [10] A. Gersho and R. M. Gray, *Vector Quantization and Signal Compression*. Massachusetts: Kluwer Academic Publishers, 1992.
- [11] J. G. Proakis, *Digital Communications*. New York: McGraw-Hill, 1989.