



School of Engineering Science  
Burnaby, BC  
V5A 1S6  
veiro-ensc440-grp13@sfu.ca

---

March 5, 2007

Mr. Lakshman One  
School of Engineering Science  
Simon Fraser University  
Burnaby, BC  
V5A 1S6

Re: ENSC 440 Design Specifications for a Motorcycle Headlight Correction System

Dear Dr. One:

The enclosed document, *Design Specifications for Motorcycle Headlight Correction System*, outlines our project for ENSC 440. The goal of our project is to design and implement a system to automatically correct motorcycle headlights, when a motorcycle is travelling along a curve, in order to optimize driver safety.

We are currently in the process of ironing out the final designs required to complete this project. We have obtained the majority of our parts and the building of the project is underway. The following document provides an overview of the design and testing parameters required by the Motorcycle Headlight Correction System. The design of the various components that form the system will be described and equations provided where applicable.

Veiro Technologies Ltd. consists of four highly capable SFU undergraduate engineering students: Christopher Martens, Raul Fernandes, Tania Kwan, and Reena Bhullar. Each of these individuals brings their own unique and valuable experiences to our team.

If you have any questions or comments, please do not hesitate to contact us at veiro-ensc440-grp13@sfu.ca.

Sincerely,

A handwritten signature in brown ink that reads "Reena Bhullar".

Reena Bhullar  
Chief Financial Officer, System Integration Engineer

Enclosure: Design Specifications for Motorcycle Headlight Correction System



**Design Specifications for a**

# **Motorcycle Headlight Correction System**

**Project Team:** Chris Martens  
Raul Fernandes  
Reena Bhullar  
Tania Kwan

**Contact Person:** Raul Fernandes  
veiro-ensc440-grp13@sfu.ca

**Submitted to:** Lucky One – ENSC 440  
Steve Whitmore – ENSC 305  
School Of Engineering Science

**Issued Date:** March 5, 2007

**Revision:** 1.0

### Executive Summary

The staggering statistics of motorcycle injuries and fatalities when a rider is travelling at night and before he negotiates a curve implored the members of Veiro Technologies Inc. to investigate methods that would decrease the dangers associated under these scenarios. The innovative solution founded by Veiro Technologies will vastly increase the safety of all riders, motorists, and pedestrians.

Veiro Technologies Inc. is currently in the process of producing a Motorcycle Headlight Correction System that automatically obtains data from the motorcycle while it's in motion and relates the information to the motors controlling the headlight. Whenever necessary, the system will permit the headlight to twist and pan. The structure of the headlight and motors will allow for the headlight to be situated parallel to the road at all times. Thus, the rider's perception of his environment will immensely improve and will reduce glare towards other motorists.

When this proof of concept system is completed, it will show sponsors and the public the advantages and benefits of installing the Motorcycle Headlight Correction System on any sport bike. A stationary model of the device will be available for viewing at the time of the presentation and if time permits, a model of the device attached to a motorcycle will allow for people to see firsthand the capabilities of the system.



**Table of Contents**

Executive Summary.....	ii
Table of Contents.....	iii
List of Figures .....	v
List of Tables .....	vi
1 Introduction .....	1
1.1 Scope .....	1
1.2 Glossary .....	1
1.3 Intended Audience.....	1
2 System Overview .....	2
3 Physical and Mechanical Design .....	3
3.1 System Overview.....	3
3.2 Material Specifications.....	3
3.3 Inertia and Holding Torque Calculations.....	4
3.3.1 Pan Inertia.....	4
3.3.2 Twist Inertia .....	5
3.3.3 Holding Torques.....	6
3.4 Motor Design.....	6
3.4.1 Standard 2-Phase 1.2A Stepping Motor .....	7
3.4.2 Geared 2-Phase 2.0A Stepping Motor .....	8
3.5 Headlight .....	9
4 Electrical System Design .....	10
4.1 Microcontroller .....	10
4.2 Development Board .....	10
4.3 Power Supply.....	11
4.4 Sensors .....	13
4.4.1 Gyroscope .....	13
4.4.2 Compass.....	13
4.4.3 Speedometer .....	14
4.4.4 Potentiometer.....	15
4.5 Electrical Assembly.....	15
4.5.1 Gyroscope Wiring.....	15
4.5.2 Compass Wiring .....	17
4.5.3 Speedometer Wiring.....	18
4.5.4 Potentiometer Wiring.....	18
4.5.5 Motor Driver Circuit.....	19
5 Firmware Design .....	23
5.1 BootLoader .....	23
5.2 Sensor Reading.....	23
5.2.1 PWM System Input: Compass.....	23
5.2.2 PWM and Timer Overflow: Speedometer .....	26
5.2.3 Analog System Input: Gyroscope, Potentiometers .....	28

5.3	Motor Control .....	30
5.3.1	Velocity Profiles .....	31
5.3.2	Motor Feedback.....	32
5.3.3	Timing Interrupt Based Velocity Profile.....	33
5.3.4	Controlling the Motor Driver (H-bridge).....	35
5.3.5	Motor Current Saving Mode.....	36
5.4	Data Collection to Computer .....	37
5.4.1	Recording Real-time Data for Testing Model .....	37
5.5	Calibration Routine .....	38
5.5.1	Stationary Calibration .....	38
5.5.2	Dynamic Recalibration .....	38
6	Complete System Design .....	39
6.1	Calculating the Twist Angle .....	40
6.2	Calculating the Panning Angle.....	40
6.2.1	Motorcycle Velocity Is Less than 1km/hr.....	41
6.2.2	Motorcycle Velocity Is Between 1km/hr and 10km/hr .....	41
6.2.3	Motorcycle Velocity Is Greater Than 10km/hr .....	42
7	Test Plan.....	44
7.1	Testing Platform .....	44
8	Conclusion.....	47
9	References .....	48

**List of Figures**

Figure 2-1: Block Diagram of System Overview ..... 2

Figure 3-1: Overview of Mechanical System ..... 3

Figure 3-2: Headlight Twist and Pan Angles ..... 3

Figure 3-3: Device Model for Inertia Calculations ..... 4

Figure 3-4: Standard 2-Phase 1.2A Stepping Motor for Panning Motion ..... 7

Figure 3-5: Geared 2-Phase 2.0A Stepping Motor for Twisting Motion ..... 8

Figure 3-6: Overhead View of Hella Headlight Beam ..... 9

Figure 4-1: “Lionel” HC12 Development Board ..... 11

Figure 4-2: Electrical System of Motorcycle Involving the Battery ..... 11

Figure 4-3: Gyroscope Circuit..... 16

Figure 4-4: Compass Circuit ..... 17

Figure 4-5: Optical Detector Circuit ..... 18

Figure 4-6: Pan Angle Potentiometer Circuit ..... 18

Figure 4-7: Twist Angle Potentiometer Circuit ..... 19

Figure 4-8: Motor Driver Circuit..... 20

Figure 4-9: Current Control via Pulse Width Modulation ..... 21

Figure 4-10: Pulse Width Modulation Circuit ..... 22

Figure 5-1: Input Capture Timer Interrupt Service Routine ..... 25

Figure 5-2: Timer Overflow and Timer Input Capture for Speedometer Measurement.. 27

Figure 5-3: 1KHz Timer and Analog Interrupt Service Routine..... 29

Figure 5-4: Velocity Profile..... 31

Figure 5-5: Acceleration Profile ..... 31

Figure 5-6: ISR for 1KHz Timer and Analog Interrupts..... 32

Figure 5-7: Pan and Twist Motor Timer Interrupt Service Routines..... 34

Figure 5-8: Pan Motor Move State Machine ..... 35

Figure 5-9: Raw Data Dumping Loop for Sensor Development..... 37

Figure 6-1: Complete System Design ..... 39

Figure 6-2: Bird’s Eye View of Motorcycle Headlight Direction ..... 40

Figure 6-3: Angle of Inclination..... 42

Figure 7-1: Test Platform for Device ..... 44

Figure 7-2: Motorcycle Headlight Correction System on Test Platform..... 44

**List of Tables**

Table 1: Component Masses for Inertia Calculations.....	4
Table 2: Specifications for Standard 2-Phase 1.2A Stepping Motor for Panning Motion ..	7
Table 3: Specifications for Geared 2-Phase 2.0A Stepping Motor for Twisting Motion ....	8
Table 4: Compass Pin Numbers .....	17
Table 5: L298 Port Numbers .....	20
Table 6: HC12 Compass Connections .....	23
Table 7: Compass Output; B-Field to PWM Time .....	24
Table 8: HC12 Speedometer Connections .....	26
Table 9: HC12 Analog Peripherals Connections.....	28
Table 10: Stepper Motor Coil Firing Sequence .....	30
Table 11: Velocity Profile Interrupt Timing Array .....	33
Table 12: H-Bridge to HC12 Connections.....	36

## 1 Introduction

Motorcyclists are constantly in danger of injury or fatality when riding at night and around curves due to the limited visibility of their local environment while riding. The Motorcycle Headlight Correction System will increase a rider's vision under these circumstances. The system enables the headlight to twist and pan automatically such that the light emitted will maximize the path seen ahead of the rider. Glare seen by oncoming traffic and by pedestrians will be reduced, thus greatly improving the safety of all road users.

### 1.1 Scope

This document describes the design specifications of the Motorcycle Headlight Correction System prototype. The design requirements for major components of this proof of concept device will also be provided. Given that the project is currently under development, the final design specifications may vary slightly from those provided in this document.

### 1.2 Glossary

Compass	A device which determines the absolute angle with respect to a magnetic field, typically used on the magnetic field of the earth.
Gyroscope	A device which determines the change in angle.
Headlamp	A light bulb, typically a Halogen or Xenon mixture.
Headlight	A system typically consisting of a reflector, a headlight, a lens and an enclosed case.
Pan Angle	An angle which allows for horizontal scanning relative to the Earth's horizon.
Twist Angle	An angle made by rotation around the motorcycle's roll axis.

### 1.3 Intended Audience

The design specification documented is intended for design engineers and management personnel. The information enclosed will provide design engineers with the required specifications for producing a functioning Motorcycle Headlight Correction System. Management personnel will use the document to gauge the size of the project and to ensure that the project is on track during the product development phase.



## 2 System Overview

The following section will describe why components were selected as part of the design requirements for the Motorcycle Headlight Correction System. The overall system block diagram is shown in Figure 2-1.

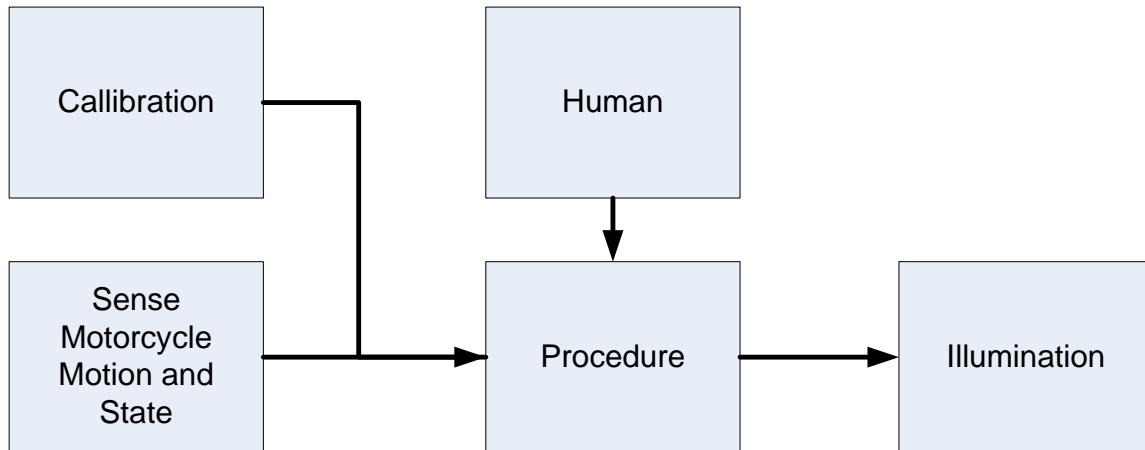

Figure 2-1: Block Diagram of System Overview

The detection of the position and orientation of the motorcycle is the first step of the process. The calibration of the system sets how the headlight correction system behaves relative to the inputs; the calibration is factory set and not end user adjustable. This process will adjust the headlight such that the longer side of the headlight is parallel to the road, thus providing maximum exposure of the rider's surrounding environment. Note that the "Human" block of the system interacts with the motorcycle which leads to an adjustment of the headlight.

### 3 Physical and Mechanical Design

#### 3.1 System Overview

Figure 3-1 shows an overview of the mechanical system.

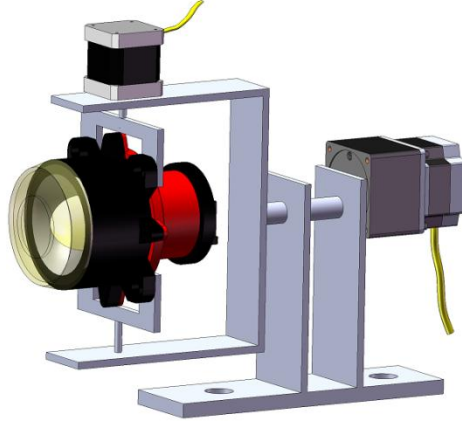

Figure 3-1: Overview of Mechanical System

This mechanical assembly will give the headlight two degrees of freedom, along the twist and pan angles. Figure 3-2 shows the twist and pan angles of the motorcycle headlight.

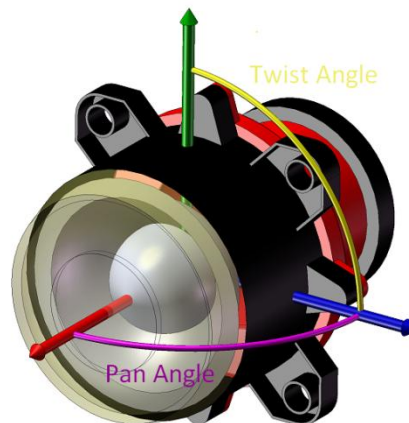

Figure 3-2: Headlight Twist and Pan Angles

#### 3.2 Material Specifications

Aluminum will be used for the construction of the proof of concept prototype. Aluminum is an ideal material for the device prototype because the material has the advantage of being light weight and manoeuvrable. It will also help us keep our costs of prototype construction low.

Stainless steel will be employed in the final production model. Stainless steel is extremely durable and weather resistant. When purchased in large quantities, the cost and performance of the material is ideal for the mass production of an automotive component.

### 3.3 Inertia and Holding Torque Calculations

Figure 3-3 shows the components of the device modeled by different shapes to allow for more flexibility in the calculations. The headlight dimensions and the rotation axes are also shown in the diagram.

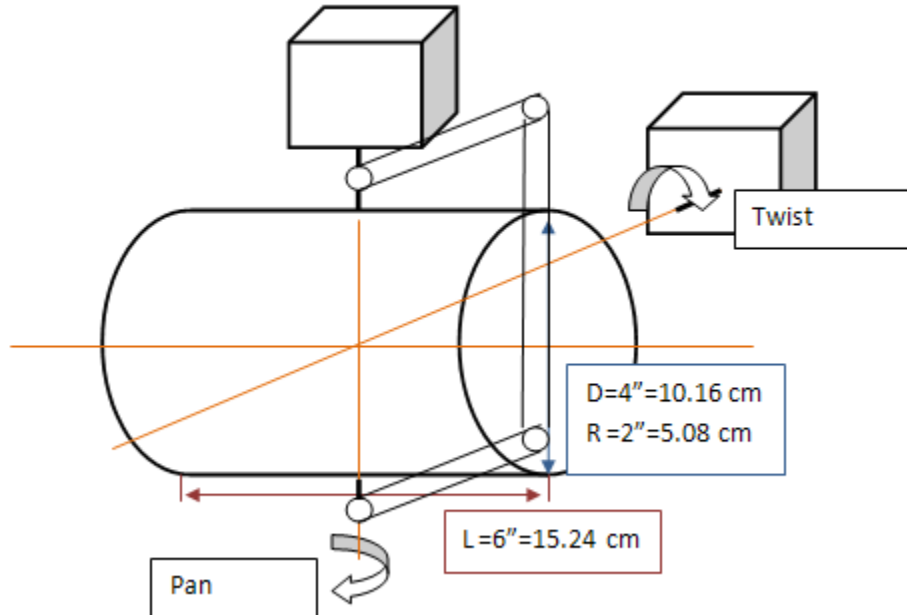

Figure 3-3: Device Model for Inertia Calculations

The values in Table 1 provide the component mass information that is required to calculate the inertia of the two motions, twisting and panning.

Table 1: Component Masses for Inertia Calculations

Component	Mass
Headlight	1.13 kg
Frame	0.1 kg
Twist Motor	0.75 kg
Pan Motor	0.35 kg

#### 3.3.1 Pan Inertia

To determine the panning inertia, the twist motor is ignored. As seen in Figure 3-3, the headlight is modeled by a cylinder. Thus, the weight of the frame can be added to the weight of the headlight, resulting in a 1.23 kg cylinder mass. To determine the pan inertia, the following equation can be used:

$$I_{pan} = \frac{1}{4}MR^2 + \frac{1}{12}ML^2$$

where M = mass (kg), R = radius of cylinder (m), L = length of cylinder (m).

Thus,

$$I_{pan} = \frac{1}{4}(1.23kg)(0.0508m)^2 + \frac{1}{2}(1.23kg)(0.1524m)^2$$

$$= \mathbf{0.00317418720 \text{ kg} \cdot \text{m}^2}$$

### 3.3.2 Twist Inertia

The total twist inertial can be found using the following equation:

$$I_{twist} = I_{headlight} + I_{pan \text{ motor}} + I_{frame}$$

The inertia of the headlight is the same as the inertia of the pan motor:

$$I_{headlight} = \frac{1}{4}MR^2 + \frac{1}{12}ML^2 = 0.00317418720 \text{ kg} \cdot \text{m}^2$$

Assuming that the motor is a point mass, where M = mass and r = distance to rotation (assuming 4cm distance from motor to outer part of headlight) = 4cm + 5.08cm = 9.08cm:

$$I_{point \text{ mass}} = I_{pan \text{ motor}} = Mr^2 = (0.35kg)(0.0908m)^2 = 0.0028856240 \text{ kg} \cdot \text{m}^2$$

Assuming the 2 parallel frame rods each have a mass of 50g, a length of 8cm, a diameter of 2cm, and the centre of the rods are 6cm from the centre of the headlight:

$$I_{parallel \text{ rod}} = I_{CM} + MR^2 ; \text{ where } R = 6cm$$

$$I_{CM} = \frac{1}{2}MR^2 = \frac{1}{2}(0.05kg)(0.01m)^2 = 0.0000025 \text{ kg} \cdot \text{m}^2$$

$$I_{parallel \text{ rod}} = 0.0000025 + (0.05kg)(0.06m)^2 = 0.0025025 \text{ kg} \cdot \text{m}^2$$

Assuming the vertical rod has a mass of 50g, a length of 14cm, and a diameter of 2cm:

$$I_{vertical \text{ rod}} = \frac{1}{4}MR^2 + \frac{1}{12}ML^2 = \frac{1}{4}(0.05kg)(0.01m)^2 + \frac{1}{12}(0.05kg)(0.14m)^2$$

$$= 0.0000829167 \text{ kg} \cdot \text{m}^2$$

Thus, twist inertia is calculated to be:

$$I_{twist} = I_{headlight} + I_{point \text{ mass}} + 2I_{parallel \text{ rod}} + I_{vertical \text{ rod}}$$

$$= \mathbf{0.01114772787 \text{ kg} \cdot \text{m}^2}$$

### 3.3.3 Holding Torques

The holding torque,  $\tau$ , is found using the following equation, where  $I$  is the inertia and  $\alpha$  is the angular acceleration in radians/s<sup>2</sup>:

$$\tau = I * \alpha$$

We can estimate the maximum angular acceleration for the twisting motion to be 50°/s<sup>2</sup>. Thus knowing the twist inertia,  $I_{twist}$ , the holding torque is:

$$\tau_{twist} = (0.01114772787 \text{ kg} \cdot \text{m}^2) \left( \frac{50^\circ}{\text{s}^2} * \frac{2\pi}{360^\circ} \right) = 0.00972822778 \text{ N} \cdot \text{m}$$

If the maximum angular acceleration for the panning motion is 20°/s<sup>2</sup>, the holding torque for the pan motion can be found using the calculated pan inertia,  $I_{pan}$  :

$$\tau_{pan} = (0.00317418720 \text{ kg} \cdot \text{m}^2) \left( \frac{20^\circ}{\text{s}^2} * \frac{2\pi}{360^\circ} \right) = 0.0011080004 \text{ N} \cdot \text{m}$$

## 3.4 Motor Design

The motors which were selected will need to be able to move the headlight assembly at a maximum angular velocity of 20 rad/s along the panning axis and 5.6 rad/s along the twisting axis. The motors also need to have a twist holding torque (Geared 2-Phase 2.0A Stepping Motor) of 0.00972822778 Nm and a pan holding torque (Standard 2-Phase 1.2A Stepping Motor) of 0.0011080004 Nm to be able to keep the headlight in place while the motorcycle is in motion. To meet Transport Canada requirements, the accuracy of vertical and horizontal headlight position will need to be within  $\pm 0.1^\circ$  and  $\pm 0.2^\circ$  of the correction position respectively. The motors also need to be compact enough to fit within the mechanical assembly.

Two 2-phase stepper motors are used in the Motorcycle Headlight Correction System because they offer balanced performance enhanced by high torque, low vibration, and low noise.

### 3.4.1 Standard 2-Phase 1.2A Stepping Motor

---

A VEXTA® PK245-01AA is utilized for the vertical panning motion due to its lighter weight and small size. Figure 3-4 shows the stepper motor.



Figure 3-4: Standard 2-Phase 1.2A Stepping Motor for Panning Motion

The relevant specifications of this motor are listed in Table 2:

Table 2: Specifications for Standard 2-Phase 1.2A Stepping Motor for Panning Motion

<b>Current per Phase</b>	1.2 A/phase
<b>Step Angle</b>	1.8 °
<b>Step Accuracy</b>	±0.05 °
<b>Maximum Holding Torque</b>	0.43 Nm
<b>Ambient Temperature Range</b>	-10 °C ~ 50 °C
<b>Ambient Humidity Range</b>	85% or less
<b>Motor Frame Size</b>	1.65 sq. in.

### 3.4.2 Geared 2-Phase 2.0A Stepping Motor

A VEXTA® PK264A2A-SG3.6 is utilized for the horizontal twisting motion. Figure 3-5 shows the motor that is used.



Figure 3-5: Geared 2-Phase 2.0A Stepping Motor for Twisting Motion

This motor is carrying more weight and needs to have a higher holding torque. A built in gearing helps this motor achieve a higher holding torque. The relevant specifications of this motor are listed in Table 3:

Table 3: Specifications for Geared 2-Phase 2.0A Stepping Motor for Twisting Motion

<b>Current per Phase</b>	2 A/phase
<b>Step Angle</b>	0.5 °
<b>Step Accuracy</b>	±0.05 °
<b>Gear Ratio</b>	3.6:1
<b>Maximum Holding Torque</b>	1 Nm
<b>Ambient Temperature Range</b>	-10 °C ~ 50 °C
<b>Ambient Humidity Range</b>	85% or less
<b>Motor Frame Size</b>	2.36 sq. in.

### 3.5 Headlight

The headlight needs to be bright enough to adequately light up the road. The pattern of the light beam has to be rectangular so that the light is properly focused on the street and not into the eyes of oncoming traffic. Our design also needs the headlight to be lightweight and compact so that it fits well into our system and can be maneuvered without the need for very strong motors.

A Hella headlight was chosen because of its lightweight and small size. The headlight is 4.61" x 4.33" x 5.60" (W x H x D) in size. These dimensions include the mounting brackets that are attached to the headlight. The shape of the beam that is projected from the headlight is shown in Figure 3-6.



Figure 3-6: Overhead View of Hella Headlight Beam



## 4 Electrical System Design

### 4.1 Microcontroller

The processing system used for the Motorcycle Headlight Correction System is a Motorola HC12. This microprocessor is responsible for gathering information from the sensors placed on the motorcycle and determining an appropriate output for the headlight. This specific model of HC12, the HC912D60A, is a 16-bit microcontroller with 60kB of low voltage programmable Flash, 1kB of Electrically Erasable Programmable Read Only Memory (EEPROM), and 2kB of Static Random Access Memory (SRAM). The CPU is capable of 0.6 Million Multiply Addition Cycles per Second (MMACS) and 8 Million Instructions per Second (MIPS).

The CPU accepts multiple sources of interrupts which are used to reduce the processor's need to poll, or constantly check the status of inputs, timers, analog to digital status, and various other sources. With the use of interrupts to run the system processes, much of the complex time sensitive routines are regulated on specific time intervals, and events are never missed because the processor was overloaded processing other items.

Peripherals of interest to the headlight correction system are the enhanced capture timer (ECT), the 10-bit analog to digital converter (ATD), the serial communication interface (SCI), and 68 pins of general purpose IO (GPIO). The SCI port allows the microprocessor to be reprogrammed with new code, and for user specific debugging during the development stage.

### 4.2 Development Board

The development board supporting the HC12 microcontroller is the "Lionel" board donated to this project by Kodak Graphic Communications Company Canada. This board supports power regulation, common serial port communication RS232 to SCI level-conversion, various headers and RC-filtering and overvoltage protection on IO and analog header pins.



Figure 4-1: "Lionel" HC12 Development Board

The "Lionel" board contains an MC68HC912D60A microcontroller, a PowerTrends 5V switching power supply, serial level converter, headers and IO banks, and several I2C buffers, Can bus interfaces, and PWM solenoid drivers which unfortunately aren't rated high enough for our motors. The board is a 6 layer, 4x6 inches, with 1oz copper making it a well laid out, stable system to work with. Noise considerations and power filtering were well developed and no parasitic problems have been detected as of yet.

The environmental considerations for this board include shielding from direct moisture, high heat, and larger components like electrolytic capacitors and switching power supplies limit the vibrations this board can take. A non-direct mounting to the frame, either through a fiberglass mount or plastic hook, will be considered when mounting to the motorcycle.

### 4.3 Power Supply

Batteries play an important role in every vehicle. It powers the components that are not or cannot be powered by the engine, particularly when the engine needs to be started. In a motorbike, the alternator generates electricity as the engine turns. This electricity is regulated by a regulator because there is more electricity being generated than what is needed by the motorcycle [2]. Thus the regulator exists for safety reasons. When a motorcycle needs to be started, the battery is what provides the electrical system with the power to ignite the engine. Once the motorcycle is started, the alternator takes over and directs the electricity to the required components, and any excess electricity is fed back into the battery for storage. Figure 4-2 shows a diagram of the system.



Figure 4-2: Electrical System of Motorcycle Involving the Battery

The Motorcycle Headlight Correction System requires the battery to power the device in order to position and orientate the headlight. In the production model of the Motorcycle Headlight Correction System, the 12V/11Amp-Hour battery from the motorcycle will provide the power to the device.

For the proof of concept model, a power supply will be used to power the device. This component is meant to act as the battery although it is a variable voltage source. Due to the fact that we are running on a regular load, the variable voltage will not have an effect on the system. The regulator will be supplied with 13.8V which will in turn send only the required 5V to the board.

## 4.4 Sensors

Multiple sensors will be utilised by the Motorcycle Headlight Correction System in order to obtain accurate motorcycle tilt angles and speeds. These measurements need to be as precise as possible because they will be used to translate and orient the headlight into the desired position.

### 4.4.1 Gyroscope

A gyroscope will be used in this project to determine the rate of change of the tilt of the motorcycle. Once this value is determined, it will be used to adjust the twist position of the headlight in order to keep the headlight beam parallel to the ground.

The ADXRS150 is a Micro Electro Mechanical System (MEMS) gyroscope with a voltage output that is proportional to the angular rate about the axis normal to the top surface of the chip. The maximum output range of the gyroscope is  $\pm 150^\circ/\text{s}$ , with a positive output voltage corresponding to the clockwise rotation about the axis normal to the top surface of the chip [3].

The dual sensor design of the ADXRS150 has excellent rejection of lateral and axial external g-forces and vibration, and the sensor also has additional signal conditioning electronics to preserve signal integrity in noisy environments. The design of the ADXRS150 is small and light, which works well with the requirement to keep the Motorcycle Headlight Corrections System as small as possible.

### 4.4.2 Compass

The CMPS03 Robot Compass Module uses two Philips KMZ51 magnetic field sensors, which are sensitive enough to detect the Earth's magnetic field, mounted at right angles to each other to compute the direction of the horizontal component of the Earth's magnetic field [4]. The output is a pulse width modulated signal with the positive width of the pulse representing the angle from magnetic north. A 1mS pulse represents an angle  $0^\circ$  and a 36.99ms pulse represents an angle of  $359.9^\circ$ . Between pulses the output signal goes low for 65ms.

A  $1\mu\text{s}$  resolution is given by using the processor's 16bit timer to generate the output pulse. However, it is recommended that the signal not be measured to an accuracy greater than  $0.1^\circ$  ( $10\mu\text{s}$ ). The compass requires a 5v power supply at 15mA. Also, as the PWM output will be utilized, the I<sup>2</sup>C pins should be connected to the 5v supply through pull-up resistors.

The compass will be used to determine the angular velocity of the motorcycle around curves at low speeds. When motorcycles maneuver around curves at speeds  $\leq 10\text{km/hr}$ , they do not tilt [5]. This compass was selected because the angular velocity is only

needed when the motorcycle is operating at low speeds. Therefore, a tilt compensated compass will not be needed.

### 4.4.3 Speedometer

---

The velocity of the motorcycle is required for the angular calculations. The motorcycle headlight correction system uses a reflective object sensor, OPB704, to obtain the velocity. The sensor is an infrared emitting diode with an NPN silicon transistor. When a reflective object passes in front of the infrared diode, the phototransistor responds. The advantages of using this type of sensor are that it contains a phototransistor output, the high sensitivity of the sensor, and the low cost of the plastic housing. It also has a diverse operating temperature range of -40°C to 85°C [6]. The utilization of a non-contact device also allows for longer use of the device and less “wear-and-tear”.

The sensor will be placed on the frame adjacent to the tire brake, with the infrared sensor pointing towards the brake. The sensor is to be placed 3.81mm from the brake disk for optimal results. When the sensor encounters the metal component of the brake, the output will be a 1; otherwise, the sensor output will be a 0.

The Kawasaki motorcycle uses a 100/80-16 50S tubeless front tire. The radius of the tire is 0.29m. The circumference,  $C$ , of the front tire is found using the following equation:

$$C = 2\pi r = 2\pi(0.29 \text{ m}) = 0.58\pi \text{ m}$$

The front tire disk brake contains eight equally-spaced holes. Thus, the distance that is travelled (i.e. circumference of the tire) between each hole is calculated to be:

$$d_{\text{tire}} = \frac{C}{8} = \frac{0.58\pi}{8} = 0.0725\pi \text{ m}$$

If  $N$  equals the number of metal surfaces on the disk brake (output is 1) encountered by the sensor and  $t$  is the time (in seconds) taken to detect  $N$ , then the velocity,  $v$ , of the motorcycle can be calculated using the following equation:

$$v = \frac{d}{t} = \frac{N(d_{\text{tire}})}{t} = \frac{N(0.0725\pi)}{t} = \frac{0.2277655N}{t} \text{ m/s}$$

For the final production of the Motorcycle Headlight Correction System, it would be advantageous to use the speedometer indicator on the motorcycle, after conversion to meters per second (m/s), directly in the angle calculations. For safety and time constraint purposes, the prototype calculates its own velocity.

#### 4.4.4 Potentiometer

---

The headlight is moved using stepper motors which allow it to be positioned very accurately. However, due to the way in which stepper motors operate, error can creep in when steps are skipped due to miscommunication between the motor and the controller or from the headlight moving out of position when it experiences large torques during the motorcycle's motion. To solve these issues, we use two angular potentiometers to determine the position of the headlight along the twist and pan angles. The two angular readings are then used by the microcontroller to correct the final headlight position. The potentiometers also help detect the initial position of the headlight when the system first starts up and let us implement a hardware based motor-disable safety feature which is described in the electrical assembly section.

The potentiometers are connected directly onto the axel of the motors, and give the microcontroller the accurate positions of the axels. A 10-turn potentiometer is used to read the twist angle while a 1-turn potentiometer is used for the pan angle. The motor that drives the twist rotation is geared with a gear ratio of 3.6:1. Thus although the headlight twist angle only has a  $\pm 60^\circ$  range, its axel has a  $\pm 216^\circ$  range; this is why a 10-turn potentiometer is employed.

### 4.5 Electrical Assembly

---

The readings to and from the various motors and sensors are conditioned before they can be used by the system, the following section describes the electrical design of the various subcomponents of the electrical system. Gauge 24 (0.51054 mm) copper wire is used for most of the subcomponent wiring because it is thinner and more flexible to work with in tight spaces. Gauge 15 (1.45034 mm) copper wire is used between the power subcomponent devices because it is more durable and has greater power carrying capabilities suitable to carry 2A of current.

#### 4.5.1 Gyroscope Wiring

---

The gyroscope wiring for connection to the microcontroller is shown below in Figure 4-3. The 3-pin jumper is used for ST1 and ST2. There is a bypass capacitor of 0.1uF to filter the AC component, thus allowing the DC to pass through.

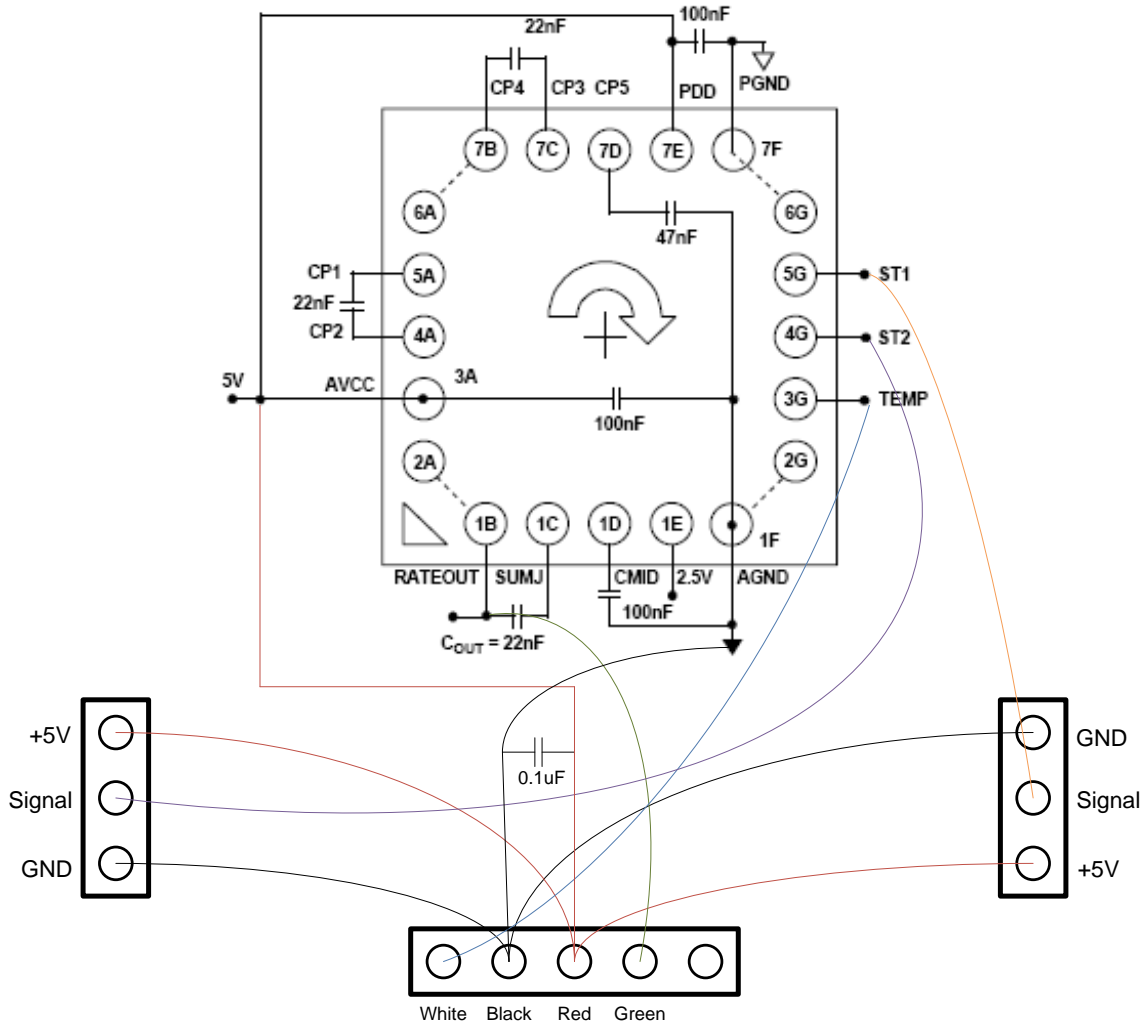

Figure 4-3: Gyroscope Circuit

### 4.5.2 Compass Wiring

The compass wiring that allows for the compass to connect to the microcontroller is shown below in Figure 4-4. An RC-filter is used here to filter the AC component, thus lessening the noise that is passed to the circuit.

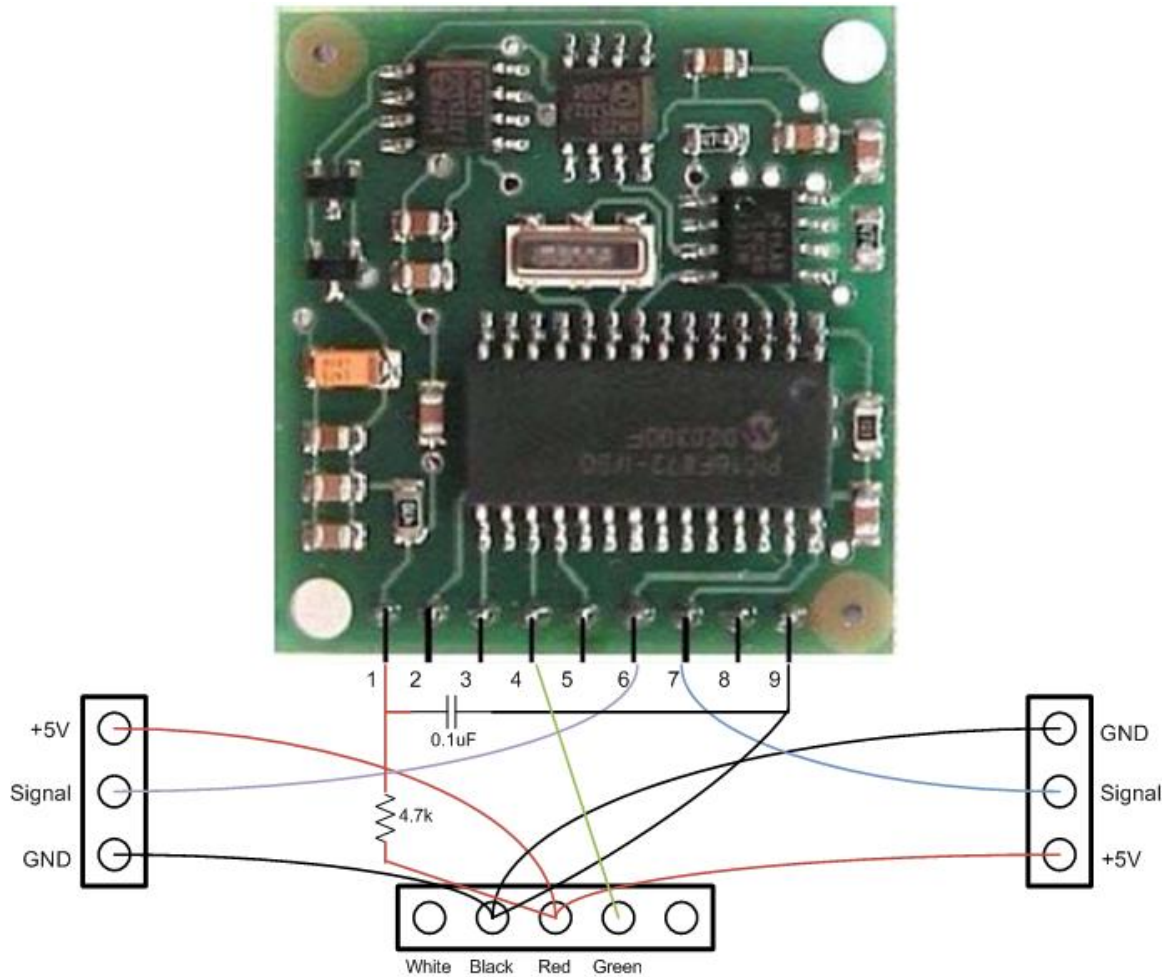

Figure 4-4: Compass Circuit

The corresponding connections to the compass module are shown in Table 4.

Table 4: Compass Pin Numbers

Pin Number	Type
1	+5V
2	SCL
3	SDA
4	PWM
5	No Connect
6	Calibrate
7	50/60 Hz
8	No Connect
9	Ground



### 4.5.3 Speedometer Wiring

The wiring of the optical detector that is used to measure the speed of the motorcycle is shown in Figure 4-5.

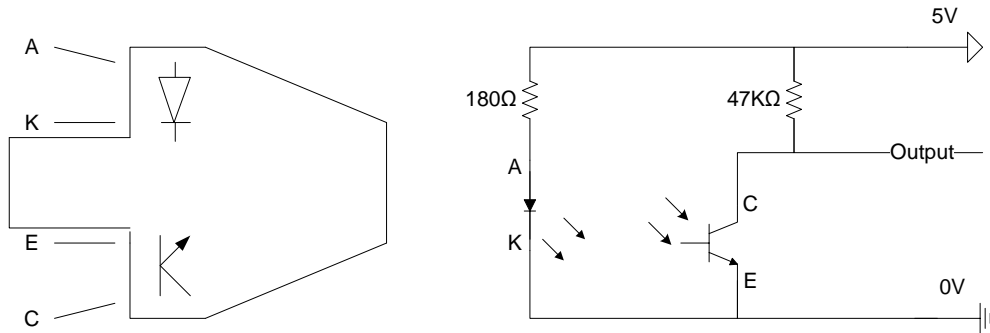

Figure 4-5: Optical Detector Circuit

### 4.5.4 Potentiometer Wiring

The pan angle potentiometer circuit schematic is shown below in Figure 4-6. The circuit consists of the potentiometer that reads the pan angular position of the headlight and the output of this sensor is fed directly to the microcontroller.

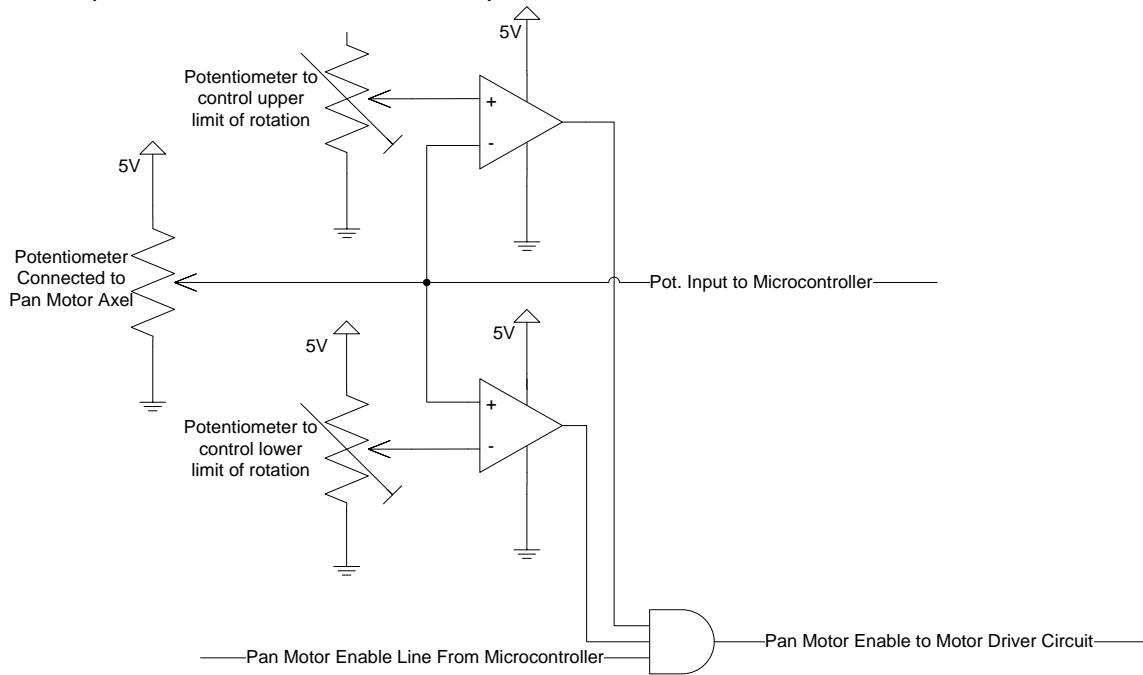
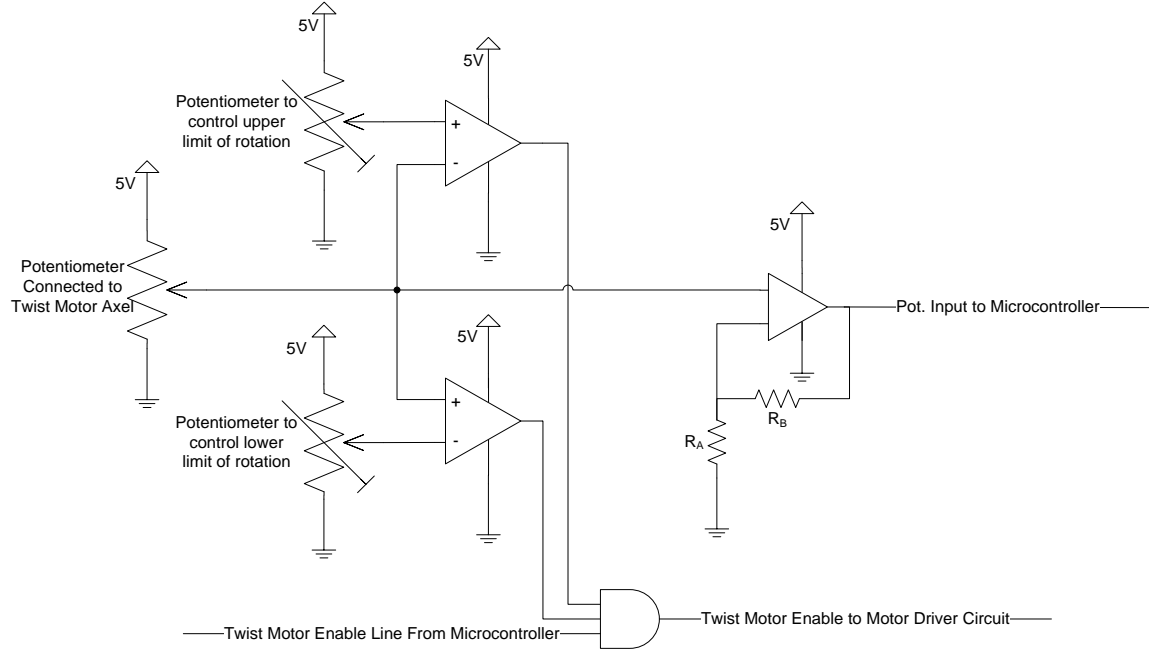

Figure 4-6: Pan Angle Potentiometer Circuit

Two other fixed potentiometers are employed along with operating amplifiers configured as comparators to implement a hardware-based motor cut-off feature. The two fixed potentiometers are used to set the operating range of the motor; if the motor

axel moves out of the safety bounds set by the two fixed potentiometers the motor is disabled to prevent damage to the system.

Figure 4-7 shows the twist angle potentiometer circuit. This circuit has a safety cutoff feature that is identical to the one described for the pan angle circuit above.



**Figure 4-7: Twist Angle Potentiometer Circuit**

The twist angle circuit has an additional amplifier component attached to the potentiometer output. The pan angle uses a 10-turn potentiometer, but the actual operating range is only  $\pm 216^\circ$ . For the potentiometer running off a 5V potential difference, the maximum unamplified output voltage of the pan potentiometer would be given by,

$$\frac{216^\circ \times 2}{360^\circ \times 10} \times 5 = 0.6V$$

This voltage range would be extremely small and insufficient to satisfy the resolution requirements the system demands. Hence an amplifier is employed to magnify this voltage almost eight times and give the microcontroller a reading with a higher resolution.

#### 4.5.5 Motor Driver Circuit

A separate motor driver circuit is employed for each of the stepper motors. Figure 4-8 shows the schematic of the driver circuit we designed. The stepper motor control-signals that the microcontroller sends out are not strong enough to drive the motors.

The driver circuit takes the four microcontroller output signals and supplies them to the motor coils with more current.

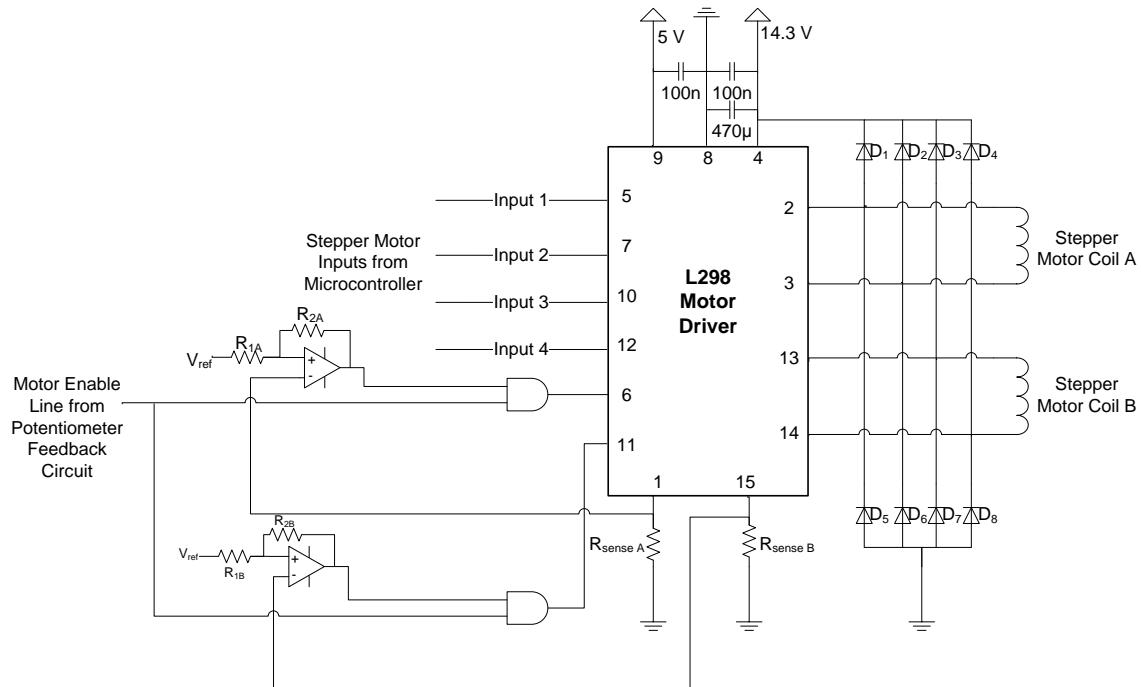

Figure 4-8: Motor Driver Circuit

The motorcycle headlight correction system employs the L298 Motor driver chip because of its price and ease-of-use. Table 5 shows what the port numbers on the L298 in Figure 4-8 correspond to.

Table 5: L298 Port Numbers

Port Number	Type
1	Current Sensing A
2	Output 1 To Motor Coil A
3	Output 2 To Motor Coil A
4	Supply Voltage $V_s$
5	Input 1 from Microcontroller
6	Enable Coil A
7	Input 2 from Microcontroller
8	Ground
9	Logic Supply Voltage $V_{ss}$
10	Input 3 from Microcontroller
11	Enable Coil B
12	Input 4 from Microcontroller
13	Output 3 To Motor Coil B
14	Output 4 To Motor Coil B
15	Current Sensing B

Eight fast-switching Schottky diodes are connected to the motor coils to drain the back EMF generated by the coils and stop the EMF from damaging the driver chip. The input power to the L298 power amplifier is filtered using capacitors to ensure that clean voltage is supplied to the chip.

The pan and twist motors are rated at 1.2A and 2.0A respectively, hence the current through the coils of the motors have to be limited to the rated current. A simple way to limit the current would be to just increase the resistance in the circuit or alternatively to reduce the supply voltage that the motor is run off so that  $V_{supply} = I_{coil}R_{circuit}$ . However, the stepper motor loses torque when run on a lower voltage.

So, to run the motor at a high voltage and with a limited current, the system modulates the pulse width of the voltage supply instead. Figure 4-9 shows how pulse width modulation can be used to control the current through the coils. When the current through the coils goes above the rated level, the input voltage is turned off until the current comes back down to the required level.

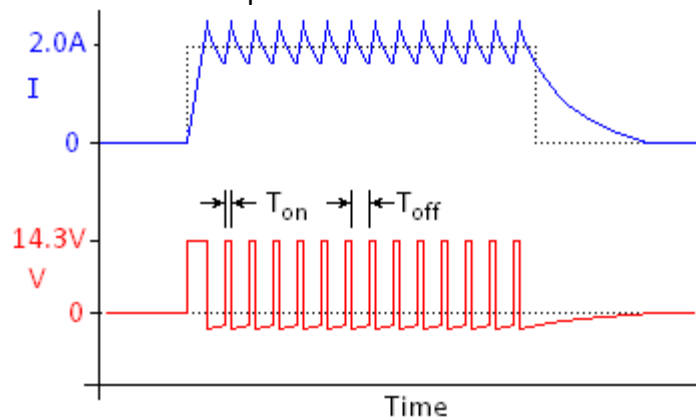
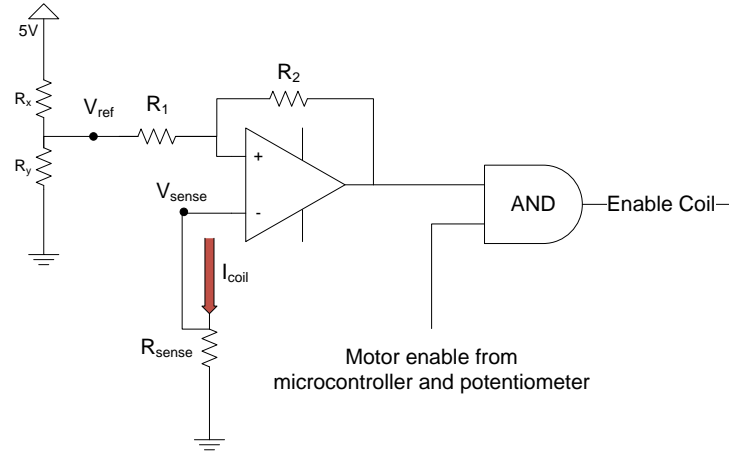

Figure 4-9: Current Control via Pulse Width Modulation

The sense resistors shown in Figure 4-8 are used to detect the current flowing through the coils. The current control circuit employs  $0.1 \Omega$  1.0 watt metal film resistors for  $R_{sense A}$  and  $R_{sense B}$  since they have a minimal effect on the current through the system. By comparing the voltage across the resistors to a reference voltage, the current chopping circuit detects when the current in the system exceeds the required value. The appropriate reference voltage for the 1.2 Ampere pan motor is set at  $V_{ref} = IR = (1.2A)(0.1\Omega) = 0.12 V$ , and for the 2.0 Ampere twist motor the reference voltage is set at  $V_{ref} = 0.2 V$ . These reference voltages are generated using a voltage divider. The motor coils are turned on and off using the enable inputs of the L298. Figure 4-10 shows the pulse width modulation component of the circuit in Figure 4-8.



**Figure 4-10: Pulse Width Modulation Circuit**

The two resistors on each comparator,  $R_{1A}$ ,  $R_{2A}$  and  $R_{1B}$ ,  $R_{2B}$  are placed in to provide hysteresis to the comparator. The values of  $R_1$  and  $R_2$  are chosen so that  $V_{ripple} \geq V_{hysteresis}$ . Where,

$$V_{ripple} = I_{ripple} R_{sense}$$

$I_{ripple}$ : the maximum coil current ripple allowed in the current

and,

$$V_{hysteresis} = V_{swing} R_1 / (R_1 + R_2)$$

$V_{swing}$ : the voltage swing at the output of the comparator

Solving these equations for the ratio of resistances,

$$\frac{R_1}{R_1 + R_2} \leq \frac{I_{ripple} R_{sense}}{V_{swing}}$$

For  $R_{sense} = 0.1\Omega$ , a voltage swing of 4 volts at the output of the opamp, and if we intend to regulate current to within 10 milliamps, a resistor ratio of at most 0.00025 is needed, which means  $R_2$  has to be a lot larger than  $R_1$ .

## 5 Firmware Design

### 5.1 BootLoader

The MC69HC912D60A has a special bootloader provided on Freescale's webpage which must be loaded into the boot-protected sector \$E000-FFFF using a Background Debug Mode (BDM) loader. These loaders allow the microcontroller to write to areas which would normally be restricted when running in normal mode.

The bootloader works by using a Xon/Xoff software controlled flow control over the SCIO (regular serial port) from a terminal program. The S19 code, Motorola's hex format for addressing and storing op-codes to be written into flash, is specially formatted into different length lines, and then downloaded into the module.

To select modes of either downloading new code to the module, or running the microcontroller in normal mode, 2 jumpers must be shorted to change between modes. To save development time and frustration dealing with small jumpers, a dual pole dual throw (DPDT) switch was installed on these two jumpers to speed up development.

### 5.2 Sensor Reading

#### 5.2.1 PWM System Input: Compass

##### 5.2.1.1 Compass to Firmware Pin connection

Because the measurement of the compass uses the timer input compare function, the PWM input to the system must be made through PortT in order to utilize timer interrupts. Below, in Table 6, the HC12 to compass connections are shown.

Table 6: HC12 Compass Connections

Description	HC12 Pin Connection	Compass
<b>PWM</b>	PortT.0	PWM
<b>I2C SDA</b>	Not Connected	SDA
<b>I2C SCL</b>	Not Connected	SCL
<b>Calibrate</b>	Not Connected	Calibrate

### 5.2.1.2 Compass Output to Degree Conversion

The digital output system from the compass module has a pulse width modulated output representing the compasses orientation to the B-field. The output pulse to angle translation is shown below in Table 7.

**Table 7: Compass Output; B-Field to PWM Time**

B-Field Angle	Pulse Width Time (ms)
<b>0</b>	1
<b>1</b>	2
<b>359</b>	36.0
<b>359.9</b>	36.99

To enable a timer to have a range from 37ms to 1ms, with 16-bit capturing timers measuring both the rising edge, and the falling edge, the timer prescale factor, or how fast the timer increments based on the 8MHz bus clock is calculated as follows.

$$0.03699s \leq counter\_Rate \times 2^{16}$$

$$counter\_Rate = \frac{Prescalar}{8MHz}$$

From this, we see that timer resolution can be set to 8, but to leave ample room for low speed (high time) velocity readings, 64 will be chosen to enable the timer not to roll over between waiting for the rising edge to fall. The timer clock for the entire timing system now runs at 125kHz yielding a minimum resolution of 8μs, and a maximum resolution of 0.524288s.

The system is alternated from waiting for a rising edge to occur, and only after that has occurred, the system reconfigures itself to interrupt on a falling edge where within the ISR, the system then calculates the pulse width by subtracting the two times. In Figure 5-1 below the interrupt service routine for the input compare timer is shown.

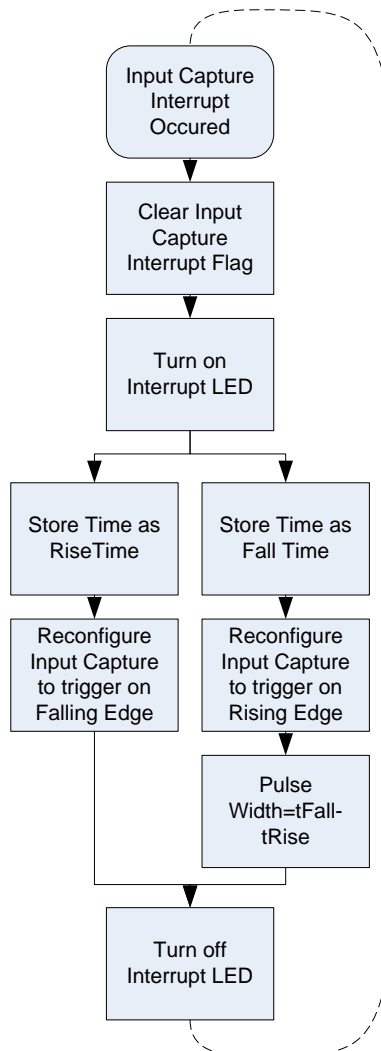

Figure 5-1: Input Capture Timer Interrupt Service Routine



## 5.2.2 PWM and Timer Overflow: Speedometer

### 5.2.2.1 Speedometer to HC12 Pin Connection

Table 8 shows the HC12 to speedometer pin connections.

Table 8: HC12 Speedometer Connections

Description	HC12 Pin Connection	Opto-reflector OPB704
Collector Voltage	PortT.1	Pin2

### 5.2.2.2 Input Compare Timer for Speedometer

To determine the speed of the motorcycle, a pulse width is measured as in the previous section. However, since the output is not guaranteed to be within the 1 to 360.9ms range like the compass module is, a smarter approach is going to be needed. When the timer overflows (the timer changes from 0xFFFF to 0x0000), an interrupt is triggered and if a rising and lowering edge has not been detected to occur within overflow periods, the system is reset to look for the rising edge.

Once the rising and falling edge occur within a time of 0.524288s, the velocity measurement begins.

$$V_{min} = \frac{2\pi(0.29)/16}{0.524288s} \cong 0.271m/s = 0.782km/h$$

In order to capture the velocity from the opto-reflective input capture timer on the HC12, the system will only enable velocity computations to happen when 1 or more rising and lowering operations happen within a timer overflow period. Below, in Figure 5-2, the two interrupts governing speedometer measurements are shown.

The computation of velocity is a short subroutine that sets the velocity =0 if the pulse width doesn't meet the minimum pulse width, or it computes the velocity regularly in m/s if the minimum pulse width is met. Again, the constants used in calculating the speed of the motorcycle are pre-computed, and velocity is a single divide operation.

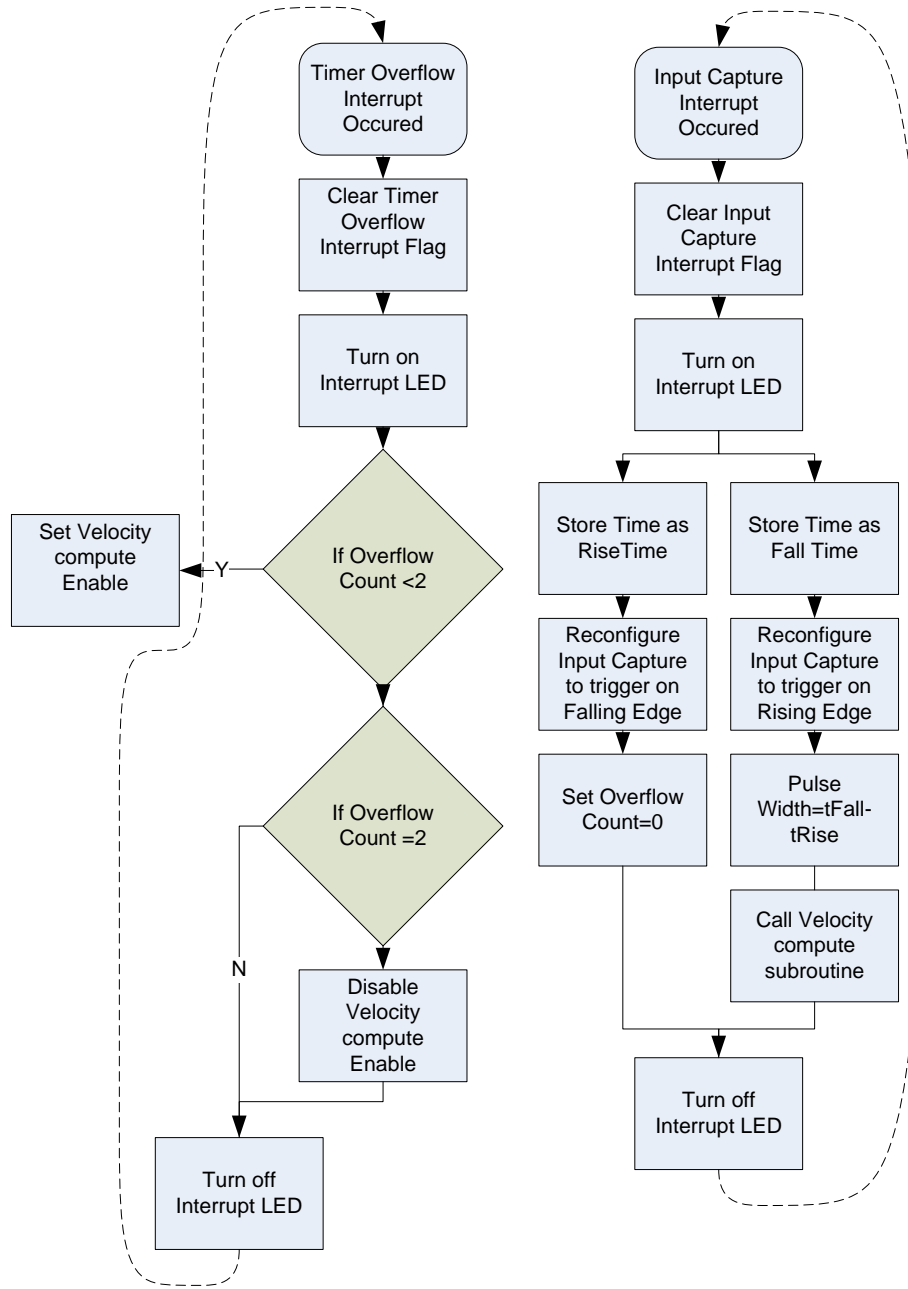

Figure 5-2: Timer Overflow and Timer Input Capture for Speedometer Measurement

## 5.2.3 Analog System Input: Gyroscope, Potentiometers

---

### 5.2.3.1 Pin connections to Analog peripherals

---

Table 9 shows the HC12 to analog peripherals connections.

Table 9: HC12 Analog Peripherals Connections

Description	HC12 Pin Connection	Analog Device
<b>Twist Motor Feedback</b>	PortA_1.0	Twist Potentiometer
<b>Pan Motor Feedback</b>	PortA_1.1	Pan Potentiometer
<b>Gyroscope Output</b>	PortA_1.2	Gyroscope

### 5.2.3.2 Process of Reading Analog Voltages

---

Reading the analog output MEMS Gyroscope, and the Pan and Twist potentiometers is executed on the interrupt of a compare timer continuously set and reset yielding interrupts on a continual time interval of 1kHz. The interrupt enable for the ATD converter is then set for the analog values to be recorded. Figure 5-3 shows the algorithm that is employed.

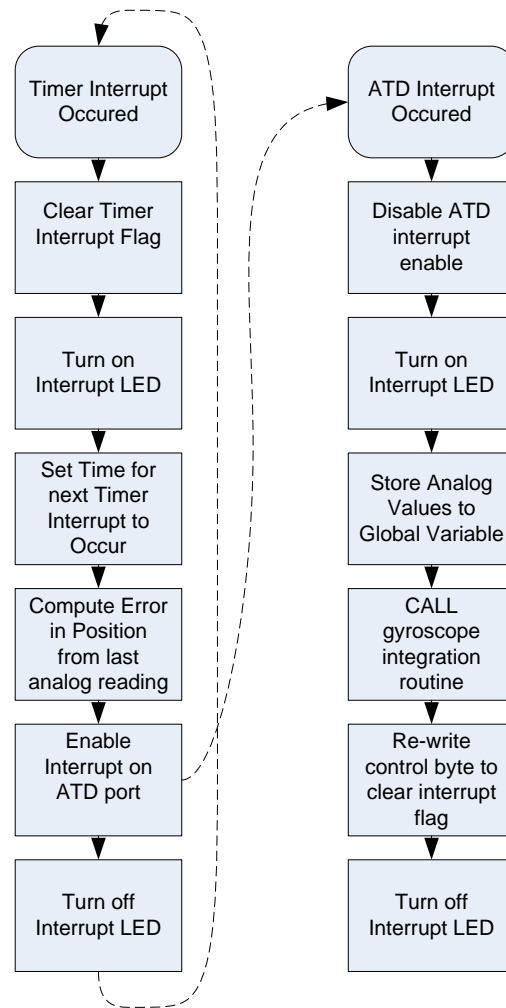

**Figure 5-3: 1KHz Timer and Analog Interrupt Service Routine**

After the interrupt enables are set for the analog port, and once the asynchronous sampling process completes, the analog interrupt triggers where the values of all three analog values are stored. The analog interrupt enables are cleared so the analog data recording routine cannot reoccur until the 1kHz timer enables the analog port.

Regulating the time between recorded analog samples enables the gyroscope integration routine to be more accurate in its use of  $\Delta t$ .

### 5.3 Motor Control

Driving stepper motors can be done in several methods ranging in complexity. The most crude is the full-step method, and the most precise is called microstepping. Full stepping alters the current from running through one coil at a time and, in essence, minimizes torque throughout rotation. Half stepping allows current to flow entirely through one coil, and in the next step current is run through the same coil and the next coil in rotation lineup. In firmware, this is accomplished by indexing through an array where individual coils are turned on according to bit assignment. In Table 10, the firing order of the motor is given for clockwise rotation.

**Table 10: Stepper Motor Coil Firing Sequence**

State	A	Not A	B	Not B
0	1	0	1	0
1	1	0	0	0
2	1	0	0	1
3	0	0	0	1
4	0	1	0	1
5	0	1	0	0
6	0	1	1	0
7	0	0	1	0

The firing sequence for the stepper motor will be stored as a static char data array where the position of the motor will be moved by incrementing through the array of values.

```
static char step_state_array[8] = {0x06, 0x02, 0x0A, 0x08, 0x09, 0x01, 0x05, 0x04};
```

The moves will be determined by a state machine which will increment or decrement through the above array of values. This odd arrangement of bytes corresponds to the switching sequence in Table 10. This is an incredibly fast method of determining the next step to make the steps turn into rotation. If the motor speed were to become an issue, a second array skipping the half-steps where two coils are driven at the same time could be used. This is a common method to speed up the rotations by eliminating the back-EMF created by driving the extra current through the coils.

### 5.3.1 Velocity Profiles

In order for the stepper motor to smoothly transition positions from its current position, to its destination, the motor must minimize torque required and therefore jerk to the mechanical system. Longevity of the mechanical system including the motors and the headlight element depend on low jerk, or quick accelerations. In Figure 5-4, the desired velocity profile is shown for a trajectory.

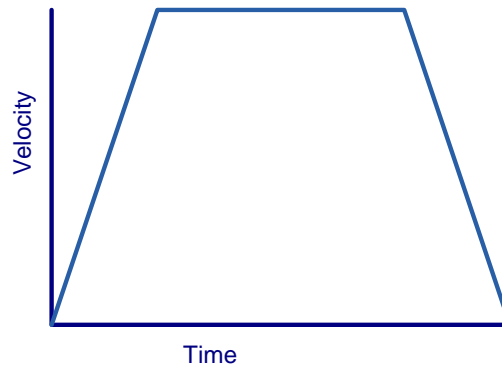

Figure 5-4: Velocity Profile

The corresponding acceleration profile is shown below in Figure 5-5.

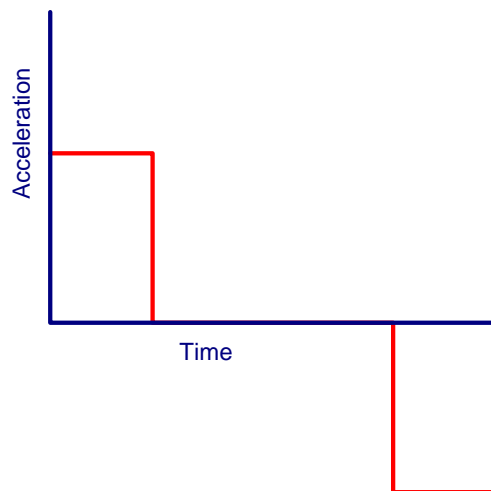

Figure 5-5: Acceleration Profile

Determining how to either accelerate or decelerate the system depends on the distance from the current position to the final position. If there are more calculated steps remaining between the current position and the final position, the system will speed up until the system figures it cannot speed up anymore without having a decrease in speed for every step toward the final position. That is, if the system has room to accelerate and decelerate such that it reaches the final destination at its slowest speed, it will do so, otherwise, it will increment steps at the lowest speed.

### 5.3.2 Motor Feedback

Motor feedback is gathered through the potentiometers attached to the drive axle of the stepper motors. This value is read in through the analog to digital converter and converted into a position within firmware. As mentioned before, the ATD measurements are gathered through interrupts fired by the ATD module whenever a reading has been completed on all 8-ports of the ATD port. A 1KHz timer is used to toggle the ATDIE register to cause an interrupt to be created on the ATD converters next completed set of values. Below, in Figure 5-6, the major steps in the interrupt service routines are shown.

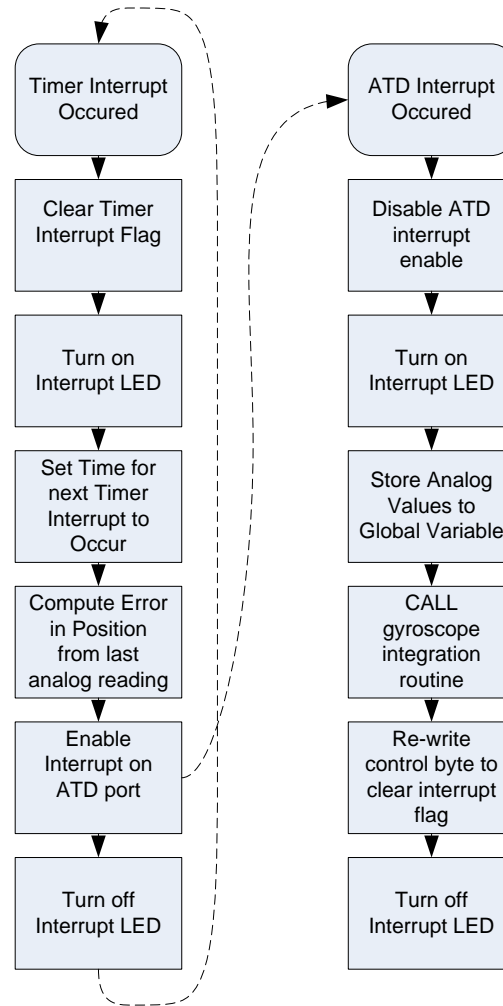

Figure 5-6: ISR for 1KHz Timer and Analog Interrupts

After the ATD interrupt has occurred, the register contents are read into global variables where the ATD values are stored.

### 5.3.3 Timing Interrupt Based Velocity Profile

The velocity profile of the above system is to be accomplished by changing the time between commands to increment the step sequence of the previous section. By changing the time between interrupts in the equation below, we essentially lessen or increase the time between certain angles moved; in the motors used in half stepping mode this will be 0.8 degrees.

$$\omega = \frac{\theta}{t}$$

An array containing the full resolution of values corresponding to time between interrupts has been created. At 16-bit, the maximum value is 65535 which is 0.525 seconds between step increments. At the lowest value corresponding to  $8\mu s$ , the stepping velocity would exceed that of the recommended speed of the motor. The stepping speed has been limited to an equivalent speed of 187.5rpm. Below we see the calculation of the minimum time between interrupts for 187.5rpm.

$$steps/s = \frac{360}{1.8/2} \times \frac{187.5rev}{m} \times \frac{1m}{60s} = 1250steps/s$$

$$t_{min} = 1/1250 = 800\mu s$$

$$Output\ Compare\ Register = \frac{800\mu s}{8\mu s} = 100$$

Below, in Table 11, we can see a constant acceleration (constant delta time) array with 25 different speed values, the lowest corresponding to 10 steps a second and the highest corresponding to 1250 steps a second.

**Table 11: Velocity Profile Interrupt Timing Array**

<pre>static unsigned int vel_profile[25] = { 12500, 12000, 11500, 11000, 10500,                                      10000, 9500, 9000, 8500, 8000,                                      7500, 7000, 6500, 6000, 5500,                                      5000, 4500, 4000, 3500, 3000,                                      2500, 2000, 1500, 1000, 500, 100};</pre>
---

The interrupt is continually called at the period of the lowest velocity until an error in position is detected, whereby the system will either increment one or two steps or alter the timers interrupt period to create a velocity profile. Below in Figure 5-7, we can see the two timer interrupts which regulate the speed of the motors separately from one another.



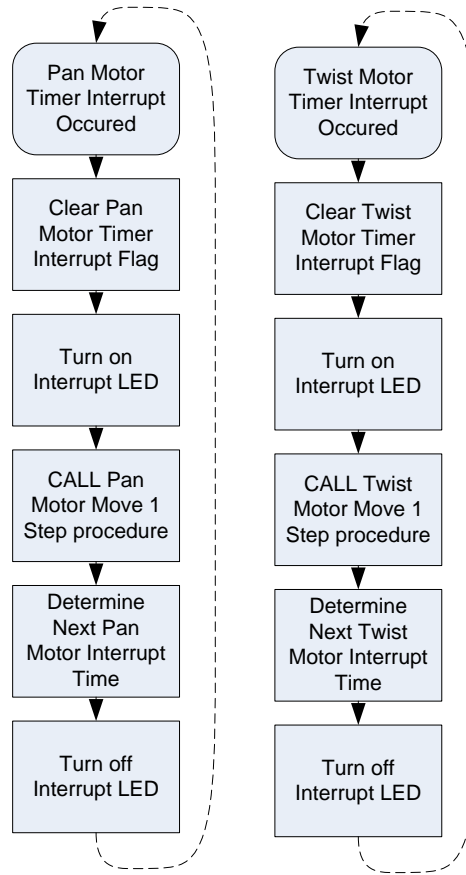

**Figure 5-7: Pan and Twist Motor Timer Interrupt Service Routines**

In each service routine, an external call is made to a procedure outlined in Figure 5-8. This routine very quickly writes the value to the H-bridge amplifier from the last known error in position. The procedure in particular looks at the global variable to do with error in position with that particular motor, and either immediately exits the subroutine back to the service routine or increments or decrements the state machine. Because we know the direction of the error, the subroutine only has to increment or decrement the next position by 1 step.

Pan Motor Move One Step

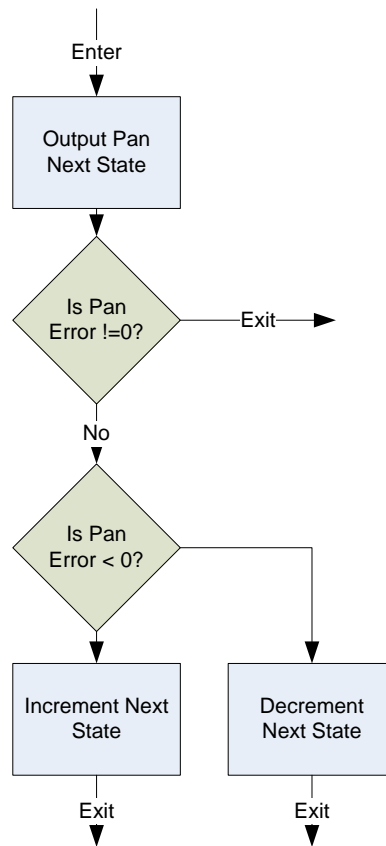

Figure 5-8: Pan Motor Move State Machine

This method of using timers on interrupts to do the calculation of time, and hence choosing the velocity, and a state machine subroutine to actually move the motors creates an incredibly fast and code efficient motor driver. Additional memory taken by the look up tables for both the state machine and the velocity profile table is much smaller than the code required to calculate in real-time the optimal next state. In addition to memory savings, the CPU computing time is reduced enabling the system to respond as fast as possible.

### 5.3.4 Controlling the Motor Driver (H-bridge)

Considerations in the firmware connections to the H-Bridge driver restrict the output char bits to be all within one port so that a write cycle will disable and enable portions of the H-bridge instantly. If various gates to the H-bridge were placed on multiple ports, the CPU would have to address each gate separately making a jerky transition from state to state. The enable line for each H-bridge can be placed on a separate port because the enable function and stepping function would never have to be synchronously set.

Below, in Table 12, we can see the ports and pins chosen to drive the H-bridge controller.

**Table 12: H-Bridge to HC12 Connections**

Function	Pan H-bridge Driver	Twist H-bridge Driver
A	PortH.0	PortP.0
Not A	PortH.1	PortP.1
B	PortH.2	PortP.2
Not B	PortH.3	PortP.3
Enable	PortE.0	PortE.1

### 5.3.5 Motor Current Saving Mode

---

Because the power required to fully drive both the motors is approximately equivalent to running an additional headlight on the bike (55W), reducing the current drawn from the motorcycle would be preferred. Battery charging, headlight, taillight and turn signal brightness, and alternator longevity are all factors to consider when using additional motorcycle power. Because we have full control of the H-bridge driver, we can disable the current when the error in position is negligible. Hence, the enable line for each H-bridge will be toggled by the 1KHz timer interrupt service routine.

Because the 1KHz timer interrupt service routine determines the error in angle and because the resolution of the feedback is higher than one step ( $0.9^\circ$ ), the motor will be kept on target strictly by re-enabling the current to the H-bridge drive.

## 5.4 Data Collection to Computer

During development of the prototype, a data collection method is essential to determine whether filtering, amplification, stability, general motorcycle movements are as expected. To gather the output's range, data dumps can be done with the SCI port where the register values are read to a computer running a serial terminal emulator program such as HyperTerm to capture data as it streams in during testing. Unfortunately bringing a computer on the motorcycle is not practical.

A program to record data values from all sensors, the gyro, speedometer, and compass to be specific, is run in the main loop and places into flash the data to be read into a computer at a later time for analysis. This will work as fast as the flash can be written to, and the control of data being recorded and dumping data will be recorded with commands sent through the SCI port.

### 5.4.1 Recording Real-time Data for Testing Model

During the development of the model, a module will be added to the main routine which will continually dump data out of the serial port to an awaiting laptop for easy data collection. A version of development firmware will contain one of two possible loops. If the results of the actual data are desired, a 1KHz compliant routine which can dump the data within the time the next 1KHz interrupt timer occurs. The second version can operate at a lower speed, but can include data for the compass, gyro and velocity inputs. The limit on the data rate is caused by the limited baud rate of the HC12. In the equation below, we can see how the data rate is determined.

$$\frac{38400\text{baud}}{16\text{bits}/\text{Sensor} \times 2 \text{Sensors}} = 1200\text{Readings}/\text{s}$$

In Figure 5-9 below, we can see the data dumping loop.

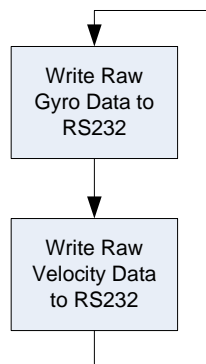

Figure 5-9: Raw Data Dumping Loop for Sensor Development

For general reading from the three movement sensors, we can make 800 readings per second.

## 5.5 Calibration Routine

Once the headlight assembly, motors, feedback devices, and sensors have been mounted to the bike with some inaccuracy, the firmware must become associated with the system. The firmware must determine, from sensor values and some level of human interaction, what is the correct headlight orientation from a cold start, and during a ride.

### 5.5.1 Stationary Calibration

For this prototype, when the user first mounts the system to the bike, the user will have to orient the headlight in the most accurate forward direction as possible. This can occur with the bike on its kickstand, or with the rider already on the bike holding it vertical. Once the rider has manually twisted the headlight to the forward pointing direction with the headlight level, the user will then push the “Set” button for the firmware to record the initial position of the headlight from the potentiometers. The integrator from the gyroscope is zeroed, and the rider is now free to move the bike around and the system will hop into the active state, realigning the headlight as the bike sits stationary, or as the rider sits and tips the bike from side to side. Due to safety regulations, the final product won’t be user calibrated. Once the calibration is factory set, the potentiometers will be used for headlight position feedback when the system first starts up. Dynamic recalibration will be used to zero the gyroscope.

### 5.5.2 Dynamic Recalibration

While the motorcycle is in motion, noise and drift may cause the digital integrator on the gyroscope to eventually develop a steady state error. To correct for this, the firmware uses a smart algorithm to detect when the bike is turning vs. moving along a fairly straight stretch of road where the bike would be level.

#### 5.5.2.1 Constant Heading Integrator Reset

When the bike is heading straight, the input from the compass will show very little change in heading (direction with respect to earth’s B-field). If the bike is moving at a high enough speed, and the heading change is low enough over an average of time, the integrator is reset so integrator is reset so  $\theta=0^\circ$ , and the motor system is then corrected with a change in position equal to that of the steady state error.

## 6 Complete System Design

The physical, electrical and firmware systems of the Motorcycle Headlight Correction System collaborate with each other to form the final product. Figure 6-1 shows a detailed overview of the entire system and how the various subsystems interact.

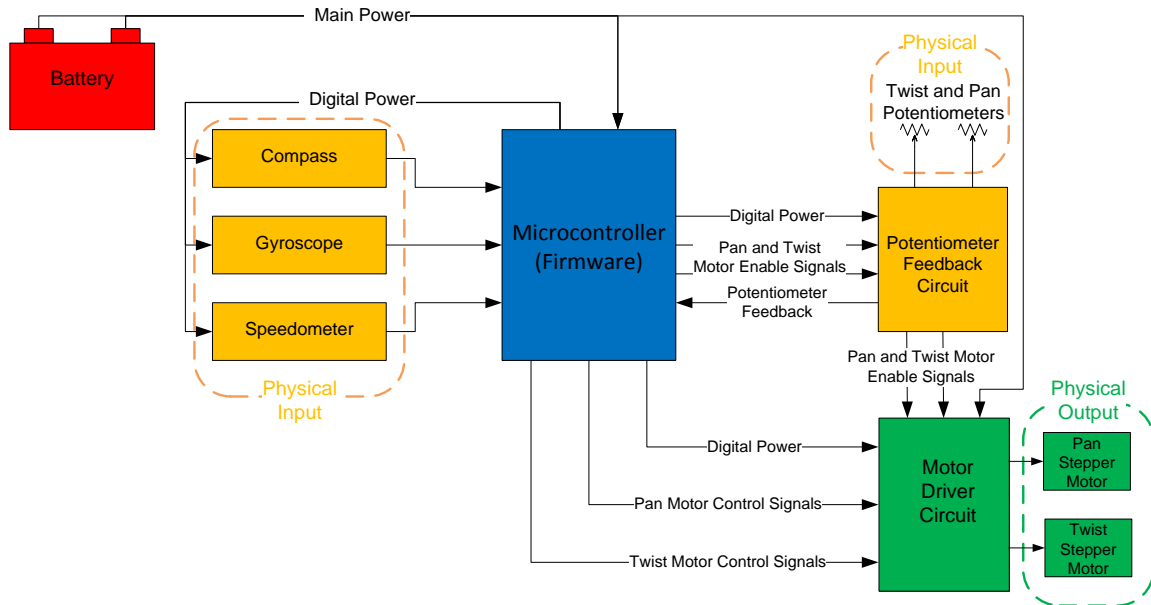

Figure 6-1: Complete System Design

The battery is the main power supply unit to the Motorcycle Headlight Correction System, it is used to directly run the microcontroller and the stepper motors. The microcontroller forms the brains of the system; all firmware is located on it. The microcontroller also supplies all the digital power (0 – 5 Volts) to the rest of the system components. The potentiometers are part of the physical input system; they let the microcontroller detect the current headlight position. The Compass, Gyroscope and Speedometer together form the other part of the physical input system. The physical input components together supply the microcontroller with the information it requires to determine the position, orientation and velocity of the motorcycle. The microcontroller analyses the information supplied by the physical input system to determine the ideal headlight position. The stepper motors form the physical output component of the system; they manipulate the mechanical assembly that holds the headlight and direct the headlight towards the required position. The next few sections describe how the system determines the ideal headlight position under different conditions.

### 6.1 Calculating the Twist Angle

The correction to the twist angle is very simple; the desired twist angle is in direct proportion to the continuous integral of the gyroscope readings. Thus, for example, if the motorcycle is tilted from 0° to 15° the headlight has to be twisted by the same angle in the opposite direction to keep the headlight parallel to the ground.

### 6.2 Calculating the Panning Angle

The panning angle calculation is considerably more complex. The design chosen to implement the panning angle correction system is a multi-part design. There are three different algorithms with this design; one for when the motorcycle has a velocity of ≤1km/hr, another for when the motorcycle has a velocity of > 1km/hr and ≤10km/hr and the last case is when the bike has a velocity of >10km/hr. Initially a design was chosen with the same algorithm for all speeds; however, this introduced the problem of compass inaccuracy. At high speeds, the motorcycle tilts over when maneuvering around curves which results in incorrect readings from the compass.

To find the angle to pan the light, we have to determine how the light should be oriented. In Figure 6-2, we can see the bird's eye view of the motorcycle headlight direction.

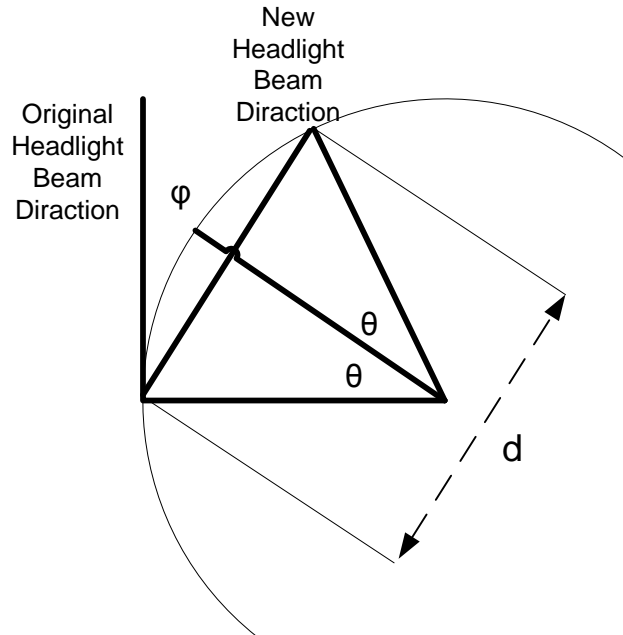

Figure 6-2: Bird's Eye View of Motorcycle Headlight Direction

Here, the headlight redirection angle  $\varphi$  can be written as:

$$\varphi = \sin^{-1} \left( \frac{d}{2r} \right) \quad (1)$$

### 6.2.1 Motorcycle Velocity Is Less than 1km/hr

---

At extremely low velocities, the inaccuracies of the other two algorithms are extremely large. Fortunately, at these low speeds there is little need for panning rotation. Hence the panning rotation is turned off under this condition.

### 6.2.2 Motorcycle Velocity Is Between 1km/hr and 10km/hr

---

When motorcycles maneuver around curves at speeds  $\leq 10\text{km/hr}$ , the tilt angle will be less than the gyroscope can measure and therefore the compass can be used to determine the angular velocity of the motorcycle around the curve.

Velocity around the curve can be calculated by applying arc length to the angular velocity conversion as follows:

$$v = \frac{2\pi r}{360} \times \dot{\theta}$$

The angular velocity  $\dot{\theta}$  is given from the output of the compass. Solving for r:

$$r = \frac{360v}{2\pi\dot{\theta}}$$

Substituting into equation (1):

$$\varphi = \sin^{-1}\left(\frac{d\pi\dot{\theta}}{360v}\right)$$

The equation above uses focal distance, d, as the variable to determine where the focal point of the headlight will be. The focal point of the headlight can also be set by using time as the variable through the equation  $v = dt$ .

$$\varphi = \sin^{-1}\left(\frac{t\pi\dot{\theta}}{360}\right)$$



### 6.2.3 Motorcycle Velocity Is Greater Than 10km/hr

At a velocity greater than 10km/hr, a method to find the twist angle of the light without using angular velocity must be developed because of the compass tilting inaccuracy and the need to pan the headlight.

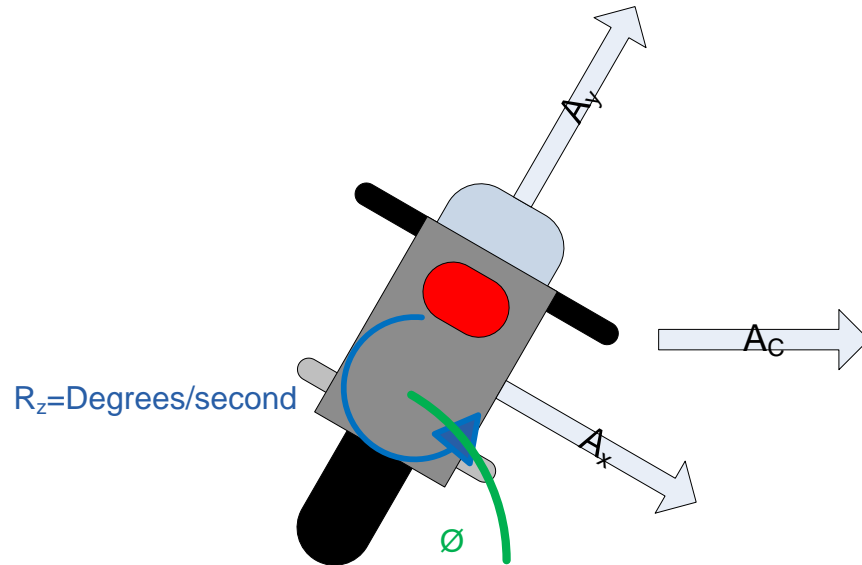

**Figure 6-3: Angle of Inclination**

The angle of inclination  $\phi$  is found from the output of the gyroscope. Relating the angle  $\phi$  of the bike and the gravitation constant  $g$  to the centripetal acceleration  $A_c$  we have:

$$A_c = g \times \tan \phi$$

The formula for centripetal acceleration is:

$$A_c = \frac{v^2}{r}$$

Combining the equations for centripetal acceleration and solving for the radius of the constant circle reveals:

$$r = \frac{v^2}{g \times \tan \phi}$$

Substituting into equation (1):

$$\phi = \sin^{-1} \left( \frac{dg \tan \phi}{2v^2} \right)$$

The equation above uses focal distance,  $d$ , as the variable to determine where the focal point of the headlight will be. The focal point of the headlight can also be set by using time as the variable through the equation  $v = dt$ .

$$\varphi = \sin^{-1} \left( \frac{tg \tan \phi}{2v} \right)$$

## 7 Test Plan

### 7.1 Testing Platform

The Motorcycle Headlight Correction System will be rigorously tested on a test platform before it is attached onto Chris' Kawasaki motorcycle. The device will be attached to one of three bases comprised of plywood. Together, the bases can be used to manually mimic the motions of a motorcycle as it is moving around a curve. It will mimic the motorcycle tilting and turning. Figure 7-1 shows how the test platform will look.



Figure 7-1: Test Platform for Device

Figure 7-2 shows how the motorcycle headlight correction system will be mounted on the test platform. The two different views show how the system should reorient itself when the platform moves. The headlight should always remain parallel to the ground and should pan in the direction in which the platform is rotating.

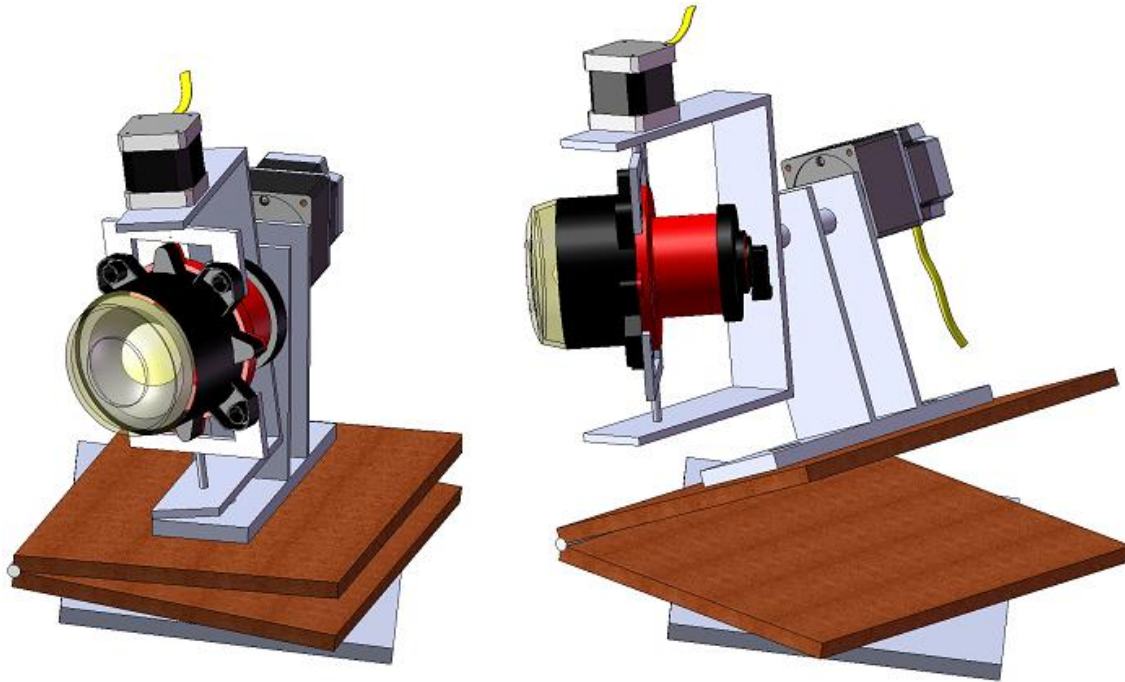

Figure 7-2: Motorcycle Headlight Correction System on Test Platform

By using a test platform, the software, firmware, and mechanics of the device can be tested immediately. Device performance can be verified accurately to ensure that it is in agreement with the calculated theory. Changes that are made using the results of these experiments can be tested right away. Thus, a tremendous amount of time will be saved while testing the system. Also, the test platform will be much more maneuverable during testing than the motorcycle. Since the test platform acts as the motorcycle, it will be easier to tilt and turn the “motorcycle” during testing.

The mechanical components of the design need to be tested to ensure various safety concerns are addressed. By rotating the test jig in a range of movements, the resulting movement of the frames and headlight will be observed. A smooth movement is expected to the point where the beam of light’s motion is perceived as smooth and not choppy. The motorcyclist should observe the beam moving in a continuous manner and not detect the step size of the motor. Shaking the test jig at various angles will have the same effect as driving on a rough road. This movement should have no effect on the system proposed as it does not compensate for vertical motion. The headlight should continue to illuminate the road in the direction of travel unless the motorcycle tilts horizontally or manoeuvres a curve. To test the limits of motion of the headlight, the test jig will be rotated at angles equivalent to or exceeding the limits of the handlebar movements. The headlight should continue to point in the direction of motion and not move to a position unusable or unsafe to the motorcyclist.

The electrical components of the design need to be tested to certify they achieve safety standards and do not harm the motorcyclist. To test the electrical components, varying currents and voltages (approaching limits) will be applied and the results will be recorded. All results should meet current safety standards set by IEEE, Transport Canada, etc. Noise immunity will also be tested to make certain there are no unexpected outcomes. High levels of noise applied to sensitive devices should not affect their performance, i.e. no change in output should occur.

The firmware of the design needs to be tested to ensure no data or processor errors will crash the system. The reliability of the microcontroller’s data retention will be tested by sending and processing data at a rate higher than expected and recording the results. The results should be equivalent to those found at the planned processing rate. By testing the interrupt service routing and firmware crash prevention system with extreme values as well as expected values, it will be ensured that they will not fail during runtime.

The system integration will be tested to make certain all components work together seamlessly. When all sensors are working and running together, their accuracy will be tested at various angles and speeds to ensure they do not interfere with each other. The output after integration should be equivalent to their individual expected performances. With all components running together, large and small changes will be made to the test jig to determine the accuracy with which the headlight assembly can

be controlled. The accuracy should be high enough that the motorcyclist cannot recognize any error.

Production model testing is needed to ensure packaging and motorcycle placement does not affect the output of the system. The model should be able to operate in a temperature range of -10°C to 50°C without any performance error. Excessive usage should result in the expected performance with regular usage conditions.

## 8 Conclusion

Escalating motorcycle popularity and motorcycle fatalities in recent years has led to an increasing demand for motorcycle and pedestrian safety. The number of the fatalities occurring at night and while maneuvering curves is alarmingly high. The Motorcycle Headlight Correction System will improve the motorcyclist's perception of his local environment by adjusting the twist and pan angles of the motorcycle headlight. By employing a gyroscope and a magnetic compass, the desired twist and pan angles can be found.

The design specifications document provides the details of how the Motorcycle Headlight Correction System will be designed and implemented. The components in this design were selected based on their ability to meet the project's functional specifications while staying within the budget of the project. Another consideration in choosing parts was their integration ability with fully sponsored components.

Headlights play a significant role in aiding motorcyclists to perceive their surroundings and, by adjusting the position of the headlight to focus in a direction that is in the rider's direct path, their effect can be maximized. The Motorcycle Headlight Correction System is designed to accomplish this goal while strictly adhering to engineering standards and upholding the most fundamental code of the APEGBC Code of Ethics: *"Hold paramount the safety, health and welfare of the public, the protection of the environment and the promotion of health and safety within the workplace [4]"*.

**9 References**

- [1] Motor Vehicle Standards and Research Branch, Transport Canada, "Lamps, Reflective Devices and Associated Equipment," [Online document], 2001 May, [cited 2007 Jan 11], Available HTTP:
- [2] Gemini Automotive Care, "The Electrical System: Your Car's Nerve Center," [Online document], 2005, [cited 2007 Mar 4], Available HTTP: <http://www.geminiarcare.com/services/electrical.html>
- [3] "Analog Devices ADXRS150 -  $\pm 150^\circ/s$  Single Chip Yaw Rate Gyro with Signal Conditioning," [Online Document], 1995-2007, [cited 2007 Mar 4], Available HTTP: <http://www.analog.com/en/prod/0,2877,ADXRS150,00.html>
- [4] G. Coe, "CMPS03 – Robot Compass Module," [Online Document], [cited 2007 Mar 4], Available HTTP: <http://www.robot-electronics.co.uk/htm/cmeps3doc.shtml>
- [5] H. M. Kroonen, "DVC – The Banking Technology Driving the CARVER Vehicle Class," [Online Document], 2004, [cited 2007 Mar 4], Available HTTP: [http://72.14.253.104/search?q=cache:FRP-koCiLKYJ:www.carver-engineering.com/\\_downloads/brink\\_AVEC\\_2004.pdf+banking+technology+driving&hl=en&ct=clnk&cd=3&gl=ca](http://72.14.253.104/search?q=cache:FRP-koCiLKYJ:www.carver-engineering.com/_downloads/brink_AVEC_2004.pdf+banking+technology+driving&hl=en&ct=clnk&cd=3&gl=ca)
- [6] Optek Technologies Inc., "Reflective Object Sensors: Types OPB703, OPB704, OPB705", [Online document], 1996 June, [cited 2006 Mar 1], Available HTTP: <http://www.datasheetarchive.com/search.php?q=OPB704&sType=part>
- [7] Douglas W. Jones, University of Iowa, "Current Limiting for Stepping Motors", [Online document], 1998, [cited 2007 Feb 28], Available HTTP: ["http://www.cs.uiowa.edu/~jones/step/current.html"](http://www.cs.uiowa.edu/~jones/step/current.html)